

INDUSTRIAL EQUIPMENT



Société Internationale de Produits et Services Industriels

102 rue J.-B. Charcot
92400 Courbevoie - France
☎ : (33) 01 47 68 75 00
✉ : ipsi@ipsifrance.com

☎ : (33) 01 47 89 99 39
🌐 : www.ipsifrance.com

SUMMARY

➤ ACCESSORIES OF PIPELINE :

- PLASTIC INSULATORS HS
- PLASTIC INSULATORS MS
- PLASTIC INSULATORS GK
- INSULATORS MSG
- METALFREE PLASTIC INSULATORS MF
- CASING END SEALS
- MODULAR WALL AND CASING SEALS
- WALL SLEEVES

➤ PIPELINE PIGS :

- FOAM PIGS
- SPHERES
- GAUGING - COMMISSIONING
- SEPARATION - BATCHING
- CLEANING
- PROTEUS RANGE
- BI-DIRECTIONAL
- HI-SEAL BI-DIRECTIONAL
- FLEXICAST RANGE
- DRIVING CUPS
- SCRAPER DISCS
- CLEANING BRUSH UNITS
- CLEANING PLOUGH – SCRAPER BLADES
- MONITOR RANGE
- PIG LOCATION SYSTEM
- GAS BAG
- EXPANDING PIPE STOPPERS
- VACUUM BOX



Société Internationale de Produits et Services Industriels

102 rue J.-B. Charcot
92400 Courbevoie - France
☎ : (33) 01 47 68 75 00
✉ : ipsi@ipsifrance.com

☎ : (33) 01 47 89 99 39
🌐 : www.ipsifrance.com

ACCESSORIES OF PIPELINE



Société Internationale de Produits et Services Industriels

102 rue J.-B. Charcot
92400 Courbevoie - France
☎ : (33) 01 47 68 75 00
✉ : ipsi@ipsifrance.com

☎ : (33) 01 47 89 99 39
🌐 : www.ipsifrance.com

PLASTIC INSULATORS HS

(Half ring)



In brief...

- Conventional insulator, made up from 2 half-rings which are matched exactly to the pipe diameter...
- ...making for fast assembly, since only four bolts per ring are needed.
- Stainless steel bolts (A2) or, on request, plastic bolts.



Société Internationale de Produits et Services Industriels

102 rue J.-B. Charcot
92400 Courbevoie - France
☎ : (33) 01 47 68 75 00
✉ : ipsi@ipsifrance.com

☎ : (33) 01 47 89 99 39
🌐 : www.ipsifrance.com

Ring sizes

Connection skid moulded to accommodate square nuts



Ring composed of two HS 8 half-rings for pipe diameter 218-238 mm.

HS insulators are available in many sizes, exactly matching the pipe used. (See table below).

Only 4 stainless steel bolts are required to connect the segments together.



Ring composed of two HS 4 half-rings for pipe diameter 108-124 mm.

Size chart

Type	minimum pipe Ø. (mm)	Maximum pipe Ø (mm)	skid heights
HS 2	59	68	all segments available in 16, 24, or 36 mm Skid heights
HS 4	108	124	
HS 6	160	182	
HS 8	218	238	
HS 10	273	295	
HS 12	323	343	

Material

HS insulators are made from highest quality original low pressure polyethylene (ND-PE, no reconstitutes).

This special polyethylene has the following technical features :

- high stress cracking resistance (18 h according to ATM D 1693)
- high impact strength (15kj/m² according to ISO 179/2C)
- very good compressive tenacity of ca. 10 N/mm²

- resistance to a constant temperature of 90° C and to short-term heating up to 110° C
- outstanding dielectric strength (70-80 kmm, DIN VDE 0303)
- good sliding properties

HS insulators are made of black polyethylene and are ca. 15 times more UV resistant than insulators made of white polyethylene.



Société Internationale de Produits et Services Industriels

102 rue J.-B. Charcot
92400 Courbevoie - France
☎ : (33) 01 47 68 75 00
✉ : ipsi@ipsifrance.com

☎ : (33) 01 47 89 99 39
🌐 : www.ipsifrance.com

PLASTIC INSULATORS MS

(Multi-segment)



MS
MS2

In brief...

- Conventional plastic insulators made up of bolted segments.

The segments feature one sliding and two connections skids, these being of **uniform height**.

- Only 2 segment sizes cope with all pipe diameters from 352 mm upwards which reduces designated stocking space.
- Bolts in stainless A2 steel or in plastic (on request).



Société Internationale de Produits et Services Industriels

102 rue J.-B. Charcot
92400 Courbevoie - France
☎ : (33) 01 47 68 75 00
✉ : ipsi@ipsifrance.com

☎ : (33) 01 47 89 99 39
🌐 : www.ipsifrance.com

Segment sizes and assembly



Sizes MS and MS 2 can be combined at will. Each segment connects with three stainless steel bolts (A2).

Connection skid moulded to accommodate square nuts

Assembled insulator ring made of 4 MS segments for pipe diameters 452 - 503 mm.

For ND = 100 mm: 1 MS segment.
For ND = 50 mm: 1 MS 2 segment.

EX. :ND 400 = 4 x MS
ND 450 = 4 x MS + 1 x MS 2

Selection table

Number of segments		minimum pipe Ø (mm)	maximum pipe Ø (mm)	skid heights
MS	MS/2			
3	1	352	392	all segments available in : 25, 36 or 50 mm skid heights.
4	-	403	443	
4	1	452	503	
5	-	503	554	
5	1	553	614	
6	-	604	665	
6	1	654	725	
7	-	705	776	
7	1	754	836	
8	-	805	887	
8	1	855	947	
9	-	906	998	
9	1	955	1058	
10	-	1006	1109	
10	1	1056	1170	
11	-	1107	1220	
11	1	1157	1281	
12	-	1208	1332	
12	1	1257	1392	
13	-	1308	1443	
13	1	1358	1503	
14	-	1409	1554	
14	1	1458	1614	
15	-	1509	1665	
15	1	1559	1796	
16	-	1610	1776	

Material

MS insulators are made from highest quality original low pressure polyethylene (ND-PE, no reconstitutes).

This special polyethylene has the following technical features :

- high stress cracking resistance (18 h according to ATM D 1693),
- high impact strength (15 kJ/m² according to ISO 179/2C),
- very good compressive tenacity of ca. 10 N/mm²,

- resistance to a constant temperature of 90° C and to short-term heating up to 110° C,
- outstanding dielectric strength (70-80 kmm, DIN VDE 0303),
- good sliding properties.

MS insulators are made of black polyethylene and are ca.15 times more UV resistant than insulators made of white polyethylene.



Société Internationale de Produits et Services Industriels

102 rue J.-B. Charcot
92400 Courbevoie - France
☎ : (33) 01 47 68 75 00
✉ : ipsi@ipsifrance.com

☎ : (33) 01 47 89 99 39
🌐 : www.ipsifrance.com

PLASTIC INSULATORS GK

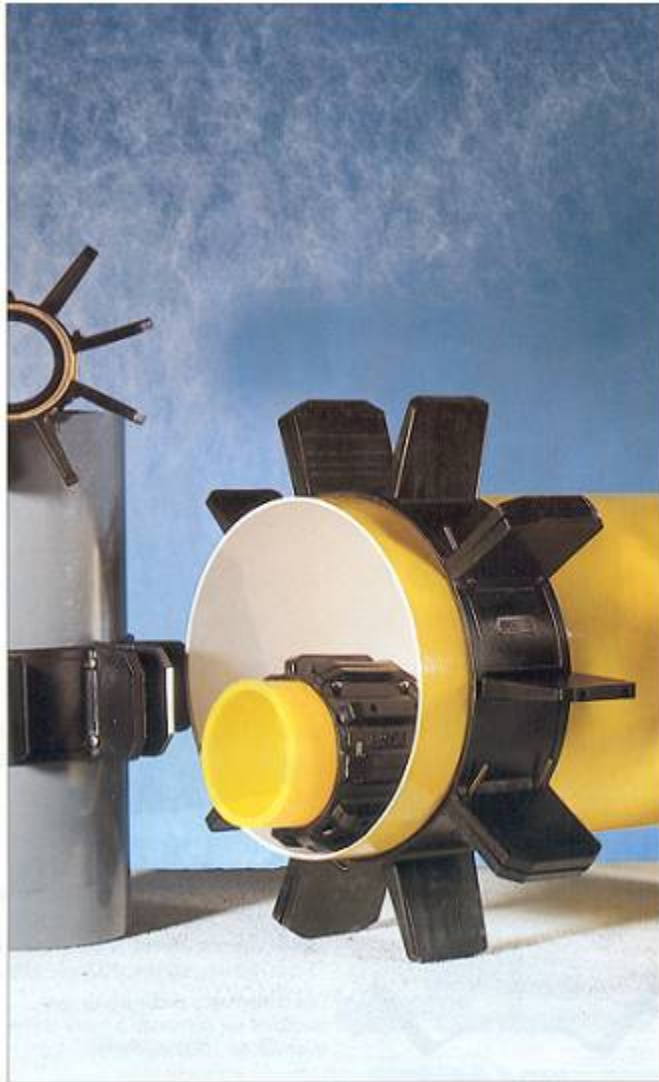

GK1
GK2
GK3

In brief...

- GK insulators are suitable for all pipes 98 to 500 mm diameter.

Three segment sizes (GK 1, GK 2, GK 3) can cope with **all** the differing pipe diameters – consequently you save on designated storage space.
- The narrower central skid allows better access to the screws – consequently you **save construction time**.
- The recent introduction of size GK 3 reduces the segment count per ring - consequently you **save on screwdriver work**.



Société Internationale de Produits et Services Industriels

102 rue J.-B. Charcot
92400 Courbevoie - France
☎ : (33) 01 47 68 75 00
✉ : ipsi@ipsifrance.com

☎ : (33) 01 47 89 99 39
🌐 : www.ipsifrance.com

Segment sizes

GK 1

Arc length : 101 mm
Width : 130 mm
3 skids.

Connects to next segment using 2 VA screws.

See table two pages on for the required number of segments per pipe diameter.



GK2

Arc length : 206 mm
Width : 130 mm
3 skids.

Connects to next segment using 2 VA screws.

See table two pages on for the required number of segments per pipe diameter.



GK3

Arc length : 260 mm
Width : 130 mm
3 skids.

Connects to next segment using 2 VA screws.

See table two pages on for the required number of segments per pipe diameter.



Skid projection



photo GK2 in 28, 65 & 125 mm skid heights.

All three segment sizes can be ordered with the following heights of skid projection :

16 mm, 28 mm, 38 mm, 50 mm, 65 mm, 75 mm, 80 mm, 90 mm, 100 mm, 125 mm.

Special skid heights can be provided from quantities exceeding 1000 segments.

Protective pipe for cable can be attached

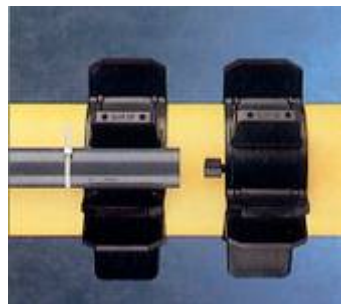

All segments are available with an injection-moulded support for cable pipes.

The cable pipe is fastened on by means of quick-lock-binders or steel tightening clamps.



Société Internationale de Produits et Services Industriels

102 rue J.-B. Charcot
92400 Courbevoie - France
☎ : (33) 01 47 68 75 00
✉ : ipsi@ipsifrance.com

☎ : (33) 01 47 89 99 39
🌐 : www.ipsifrance.com

Assembly

Segment sizes GK 1, GK 2 and GK 3 can be combined with each other at will.



assembled insulator ring using 5 GK 3 segments (for pipe diameters between 415-445 mm).

The narrower skid for a better screwdriver-access...



The middle skid of each segment is of reduced width. This gives better assembly access (for example using rechargeable screwdrivers) even with the larger skid sizes.

Assembly made simple...

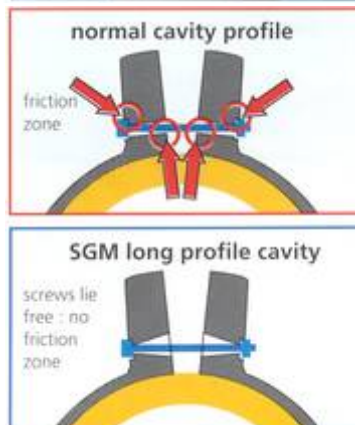

The segments are screwed together by means of square stainless steel screws (A2). The larger diameter of this type of screw's head ensures an improved contact area.

The connecting skids screw hole openings are recessed to take square profile nuts : no need to clamp the nuts during tightening.

Special profile borehole cavities ensure -even in the case of small diameter segments - that the screw lies free and does not appress the segment body.



Société Internationale de Produits et Services Industriels

102 rue J.-B. Charcot
92400 Courbevoie - France
☎ : (33) 01 47 68 75 00
✉ : ipsi@ipsifrance.com

☎ : (33) 01 47 89 99 39
🌐 : www.ipsifrance.com

Material

GK insulators are made from highest quality original low pressure polyethylene (ND-PE, no reconstitutes).

This special polyethylene has the following technical features :

- high stress cracking resistance (18 h according to ATM D 1693)
- high impact strength (15 kJ/m² according to ISO 179/2C)
- very good compressive tenacity of ca. 10 N/mm²

- resistance to a constant temperature of 90°C and to short-term heating up to 110°C
- outstanding dielectric strength (70-80 kVmm, DIN VDE 0303)

- good sliding properties

GK insulators are made of black polyethylene and are ca. 15 times more UV resistant than insulators made of white polyethylene.

Diameters table

Diameter	Number and type of segments required
98 mm -130 mm	3 Segments GK 1
131 mm -170 mm	4 Segments GK 1
171 mm - 210 mm	5 Segments GK 1
200 mm - 219 mm	3 Segments G K 2
215 mm - 235 mm	2 Segments GK 2 + 1 Segment GK 3
230 mm - 248 mm	1 Segment GK 2 + 2 Segments GK 3
245 mm - 265 mm	3 Segments GK 3
262 mm - 290 mm	4 Segments GK 2
280 mm - 310 mm	3 Segments GK 2 + 1 Segment GK 3
310 mm - 340 mm	1 Segment GK 2 + 3 Segments GK 3
323 mm - 350 mm	4 Segments GK 3
330 mm - 360 mm	5 Segments GK 2
340 mm - 380 mm	4 Segments GK 2 + 1 Segment GK 3
375 mm - 410 mm	2 Segments GK 2 + 3 Segments GK 3
405 mm - 445 mm	5 Segments GK 3
440 mm - 480 mm	3 Segments GK 2 + 3 Segments GK 3
460 mm - 495 mm	2 Segments GK 2 + 4 Segments GK 3
490 mm - 530 mm	6 Segments GK 3



Société Internationale de Produits et Services Industriels

102 rue J.-B. Charcot
92400 Courbevoie - France
☎ : (33) 01 47 68 75 00
✉ : ipsi@ipsifrance.com

☎ : (33) 01 47 89 99 39
🌐 : www.ipsifrance.com

INSULATORS MSG

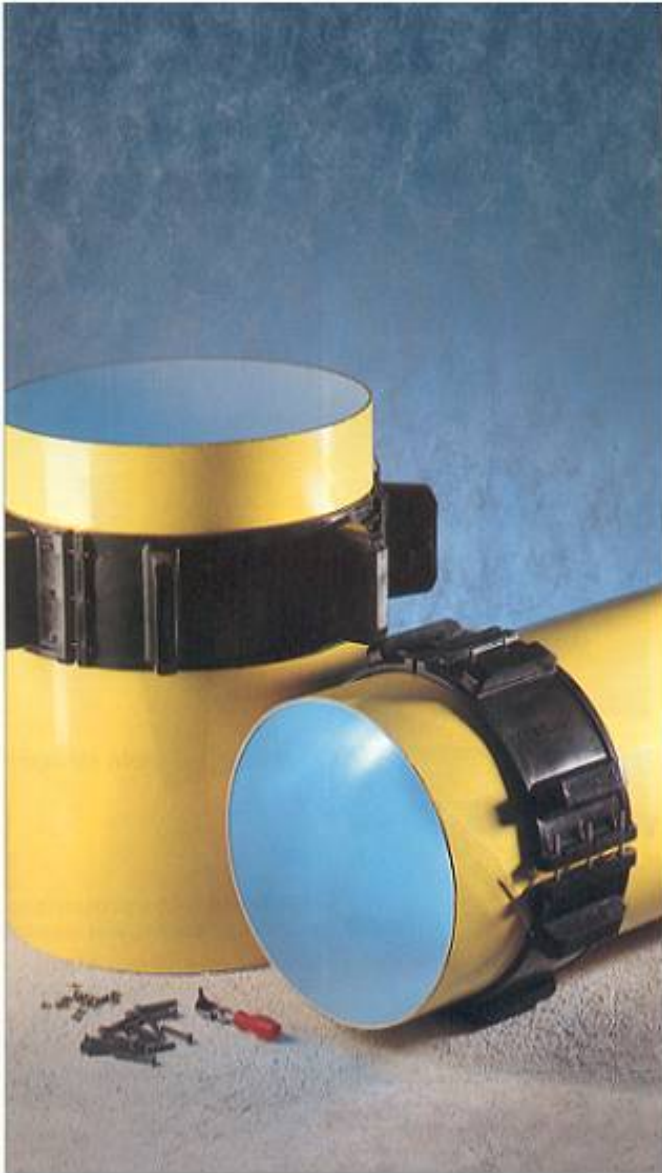

MSG 1
MSG 1,5

Insulators for large pipe diameters
upwards of 350 mm

In brief...

- MSG insulators are suitable for pipe diameters over 350 mm. Only a few segments are needed to make up a ring.
- Size MSG 1,5 reduces the number of segments required which means **less screwdriving work**.
- The connecting skirts project less than the runner skirts and carry no load, thus increasing performance and durability (higher load-bearing capacity).
- Generous dimensions and two runner skirts per segment give MSG insulators **top stability**.



Société Internationale de Produits et Services Industriels

102 rue J.-B. Charcot
92400 Courbevoie - France
☎ : (33) 01 47 68 75 00
✉ : ipsi@ipsifrance.com

☎ : (33) 01 47 89 99 39
🌐 : www.ipsifrance.com

Segment sizes

MSG 1

arc length : 314 mm
width : 170 mm
2 runner skids
2 connecting skids

The segments are connected with 3 stainless steel bolts per join.

To find out the required number of segments for a particular pipe diameter use the table two pages on.



above : MSG 1 in 25, 67 & 125 mm skid heights.

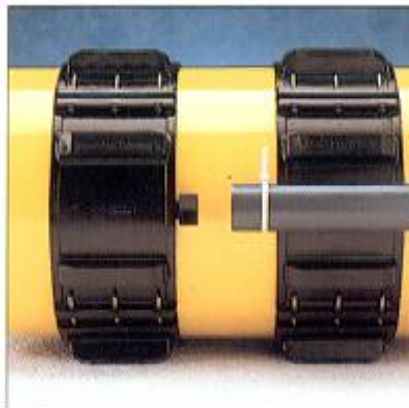

MSG 1,5

arc length : 469 mm
width : 170 mm
2 runner skids
2 connecting skids

The segments are connected with 3 stainless steel bolts per join.

To find out the required number of segments for a particular pipe diameter use the table two pages on.



MSG 1 and MSG 1,5 can be ordered with the following skid heights :

20 mm, 25 mm, 38 mm, 42 mm,
50 mm, 67 mm, 75 mm, 90 mm,
110 mm, 125 mm.

Special skid height requirements can be catered for if the order exceeds 1000 segments.

All segments are available with an injection-moulded support for cable pipe.

The cable pipe is fastened on by means of quick-lock-binders or steel tightening clamps.

Skid heights

Cable protective pipe



Société Internationale de Produits et Services Industriels

102 rue J.-B. Charcot
92400 Courbevoie - France
☎ : (33) 01 47 68 75 00
✉ : ipsi@ipsifrance.com

☎ : (33) 01 47 89 99 39
🌐 : www.ipsifrance.com

Assembly



Segment sizes MSG 1 and MSG 1,5 can be combined at will.

Assembled insulator ring consisting of 4 MSG 1 segments (to ND 400).

Connecting skids recessed to grip square nuts.

Increased performance

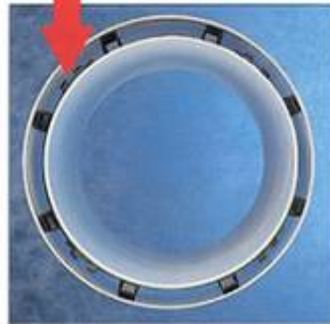

Thanks to low connecting skids which have no carrying function, MSG insulators have a higher load-bearing capacity.

Short assembly times



The connection of the segments occurs by means of square **stainless steel** bolts (A2). The bolts' heads have a larger diameter than other types of bolts in order to provide a bigger contact surface.

Because of their having a greater arc length, the number of segments required per ring decreases : **the assembly time is considerably shortened.**

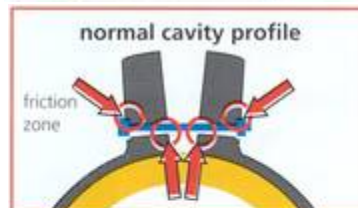

The connecting skid's borehole apertures are recessed to take square nuts - no need to clamp the nuts when tightening the bolts.

Special profile borehole cavities ensure - even in the case of small diameter segments - that the bolt lies free and does not oppress the segment body.



Société Internationale de Produits et Services Industriels

102 rue J.-B. Charcot
92400 Courbevoie - France
☎ : (33) 01 47 68 75 00
✉ : ipsi@ipsifrance.com

☎ : (33) 01 47 89 99 39
🌐 : www.ipsifrance.com

Material

MSG insulators are made from highest quality original low pressure polyethylene (ND-PE, no reconstitutes).

This special polyethylene has the following technical features :

- high stress cracking resistance (18 h according to ATM D 1693)
- high impact strength (15 kJ/m² according to ISO 179/2C)
- very good compressive tenacity of ca. 10 N/mm²

- resistance to a constant temperature of 90°C and to short-term heating up to 110°C
- outstanding dielectric strength (70-80 kmm, DIN VDE 0303)
- good sliding properties

MSG insulators are made of black polyethylene and are ca. 15 times more UV resistant than insulators made of white polyethylene.

Please note: on no account should cleaning agents or soap be used to lubricate insertion procedures ! Cleaning liquids contain substances that can cause tension-tears in PE. - with a possible consequence of a broken insulator and damage to the PE pipe coating.

Table of diameters

Pipe diameter	Number and type of segments
350 mm - 399 mm	2 Segments MSG 1 + 1 Segment MSG 1,5
400 mm - 440 mm	4 Segments MSG 1
449 mm - 491 mm	3 Segments MSG 1 + 1 Segment MSG 1,5
499 mm - 549 mm	2 Segments MSG 1 + 2 Segments MSG 1,5
548 mm - 590 mm	1 Segment MSG 1 + 3 Segments MSG 1,5
598 mm - 640 mm	4 Segments MSG 1,5
648 mm - 698 mm	2 Segments MSG 1 + 3 Segments MSG 1,5
697 mm - 749 mm	1 Segment MSG 1 + 4 Segments MSG 1,5
750 mm - 799 mm	5 Segments MSG 1,5
797 mm - 849 mm	2 Segments MSG 1 + 4 Segments MSG 1,5
850 mm - 899 mm	1 Segment MSG 1 + 5 Segments MSG 1,5
896 mm - 949 mm	6 Segments MSG 1,5
950 mm - 999 mm	2 Segments MSG 1 + 5 Segments MSG 1,5
1000 mm - 1049 mm	1 Segment MSG 1 + 6 Segments MSG 1,5
1050 mm - 1099 mm	7 Segments MSG 1,5
1100 mm - 1149 mm	2 Segments MSG 1 + 6 Segments MSG 1,5
1150 mm - 1199 mm	1 Segment MSG 1 + 7 Segments MSG 1,5
1200 mm - 1249 mm	8 Segments MSG 1,5
1250 mm - 1299 mm	2 Segments MSG 1 + 7 Segments MSG 1,5
1300 mm - 1349 mm	1 Segment MSG 1 + Segments MSG 1,5 8
1350 mm - 1399 mm	9 Segments MSG 1,5
1400 mm - 1499 mm	2 Segments MSG 1 + 8 Segments MSG 1,5
1500 mm - 1549 mm	10 Segments MSG 1,5
1550 mm - 1600 mm	2 Segments MSG 1 + 9 Segments MSG 1,5

Larger sizes on request



Société Internationale de Produits et Services Industriels

102 rue J.-B. Charcot
92400 Courbevoie - France
☎ : (33) 01 47 68 75 00
✉ : ipsi@ipsifrance.com

☎ : (33) 01 47 89 99 39
🌐 : www.ipsifrance.com

METALFREE PLASTIC INSULATORS MF

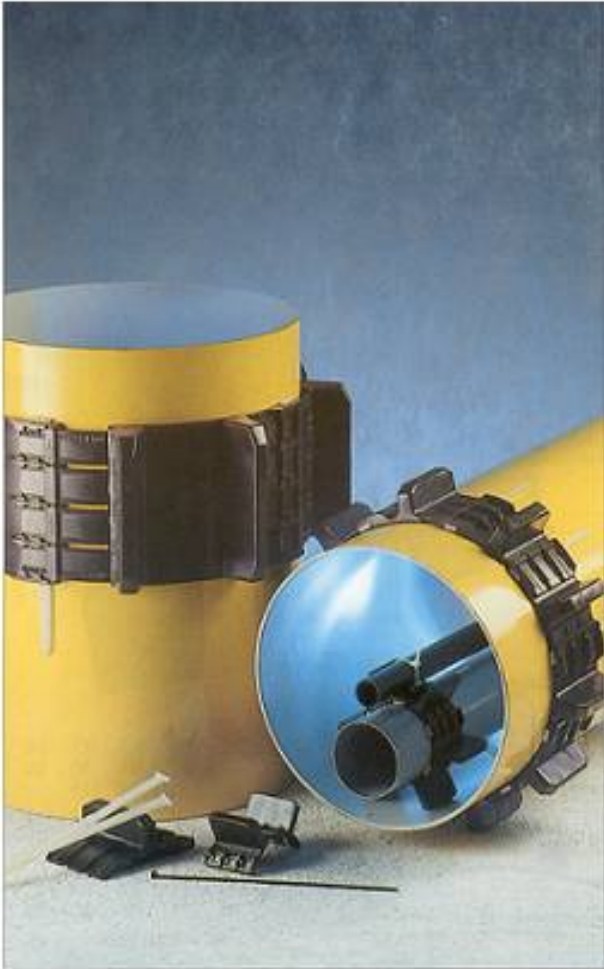

MF micro
MF mini
MF midi
MF maxi
MF maxi 0,5

In brief...

- **MF insulators (MF = metalfree)** are ideally suited for cathodically protected pipelines.
- Their patented construction means **speedier assembly times** - no more tooling around with screwdrivers or supplementary clamping implements!
- Only 5 different segment sizes - micro, mini, midi, maxi and maxi 0,5 - can cope with **all pipe diameters from ND 15 upwards**.
- The segments are linked and tightened by means of plastic pins. The flush fit of their corresponding shapes guarantees extreme endurance.



Société Internationale de Produits et Services Industriels

102 rue J.-B. Charcot
92400 Courbevoie - France

☎ : (33) 01 47 68 75 00
✉ : ipsi@ipsifrance.com

☎ : (33) 01 47 89 99 39
🌐 : www.ipsifrance.com

Segment sizes

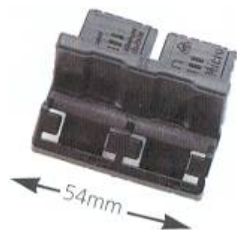

MF micro

arc length 23-33 mm, width 54 mm, 1 skid per segment.
For small pipe diameters from 21 mm (3 segments) to ca. 80 mm (8 segments).

Skid heights (in mm) :
8 ; 12,5 ; 16,5 ; 21 ; 28 ; 33 ; 44 ; 50 ; 65 ; 75 ; 90 ; 100.



MF mini

arc length 49-65 mm, width 80 mm, 1 skid per segment.
For small pipe diameters from 40 mm (3 segments) to ca. 140 mm (7 segments).

Skid heights (in mm) :
12,5 ; 16,5 ; 21 ; 28 ; 33 ; 38 ; 44 ; 50 ; 65 ; 75 ; 90 ; 100 ; 125.



MF midi

arc length 110-150 mm, width 130 mm, 1 skid per segment.
For medium pipe diameters from ca. 110 mm (3 segments) to ca. 460 mm (10 segments).

Skid heights (in mm) :
16,5 ; 21 ; 28 ; 33 ; 38 ; 44 ; 50 ; 65 ; 75 ; 80 ; 90 ; 100 ; 110 ; 125.



MF maxi

arc length 339-435 mm, width 225 mm, 2 skids per segment.
For large pipe diameters from ca. 400 mm (4 segments) to as large as they come.

Skid heights (in mm) :
21 ; 28 ; 38 ; 50 ; 65 ; 75 ; 90 ; 100 ; 125.

MF maxi 0,5 (half segment of MF maxi)

arc length 180-276 mm, width 225 mm, 1 skid per segment.
For in-between sizes, 390-550 mm (1 additional segment for Maxi).

Skid heights (in mm) :
21 ; 28 ; 38 ; 50 ; 65 ; 75 ; 90 ; 100 ; 125.

Protective pipe for cable can be attached



To find out the necessary number of segments for a particular pipe diameter use the table two pages on.

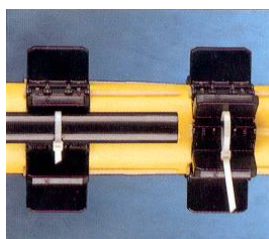

A cable pipe can be attached to all segments using quick-lock-binders (metalfree) or steel tightening clamps.



Société Internationale de Produits et Services Industriels

102 rue J.-B. Charcot

92400 Courbevoie - France

☎ : (33) 01 47 68 75 00

✉ : ipsi@ipsifrance.com

☎ : (33) 01 47 89 99 39

🌐 : www.ipsifrance.com

**Segments assembly :
speed without tools**



individual segment



Pin with slant-rib profile



two interposed units previous to the pin's insertion

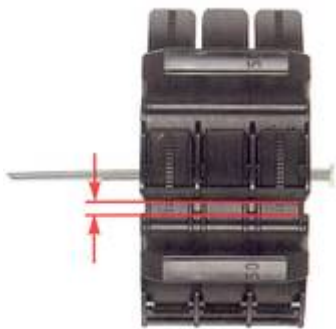
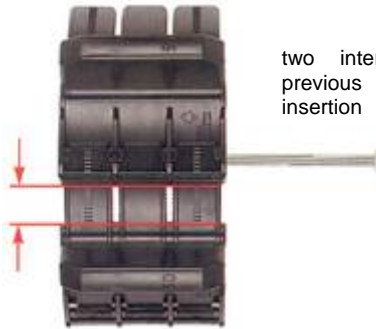

... and afterwards. The red lines indicate by just how much the segment have been tightened



completed insulator ring consisting of 8 MF mid segment units for diameter 276-376 mm.

MF insulators : assembled without fuss or additional tools a straightforward affair.

Procedure :

1. The individual units are interposed until an insulator ring is completed around the pipe.

2. The segment units are connected and tightened using a plastic pin.

What happens is that the slant rib profile of the pin slots into the ribbing of the segments, pulling both together on the pin's insertion (see drawing 1).

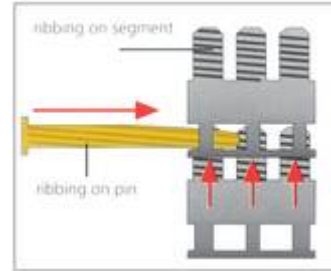

Drawing 1 : the inside view.

3. Final tension is achieved by with drawing the pin and reinserting it until the complete ring grips the pipe tightly.

The **corresponding shapes** fit exactly to **ensure an enduring connection** i.e. an high load-bearing capacity (see drawing 2).

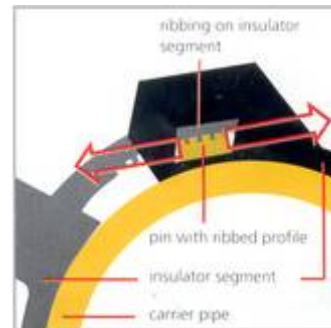

Drawing 2 : cross section view.



Société Internationale de Produits et Services Industriels

102 rue J.-B. Charcot
92400 Courbevoie - France
☎ : (33) 01 47 68 75 00
✉ : ipsi@ipsifrance.com

☎ : (33) 01 47 89 99 39
🌐 : www.ipsifrance.com

Material

MF insulators are made from highest quality original low pressure polyethylene (ND-PE, no reconstitutes).

This special polyethylene has the following technical features :

- high stress cracking resistance (18h according to ATM D 1693).
- high impact strength (15 kJ/m² according to ISO 179/2C)
- very good compressive tenacity of ca. 10 N/mm²

- resistance to a constant temperature of 90°C and to short term heating up to 110°C
- outstanding dielectric strength (70-80 kmm, DIN VDE 0303)
- good sliding properties

MF insulators are made of black polyethylene and are ca. 15 times more UV resistant than insulators made of white polyethylene.

Diameters table

Number of segments	Diameter in mm					
	MF micro	MF mini	MF midi	MF maxi	MF maxi + maxi 0,5	MF maxi 0,5
3	21-29	46 - 62	104 - 141	325 - 395		195 - 235
3 + 1 x 0,5					390 - 460	
4	29-40	62 - 83	138 - 188	426 - 546		235 - 300
4 + 1 x 0,5					450 - 550	
5	38-49	77 - 104	172 - 235	532 - 682		275 - 365
6	46-60	92 - 125	207 - 282	638 - 819		
7	55-69	107 - 145	241 - 329	745 - 955		
8	61-80	123 - 166	276 - 376	851 - 1092		
9		138 - 187	310 - 423	957 - 1228		
10		153 - 205	344 - 470	1064 - 1365		
11		169 - 228	379 - 517	1170 - 1502		
12		184 - 249	413 - 564	1276 - 1838		
13				1383 - 1775		
14				1489 - 1911		
15				1595 - 2048		
16				1702 - 2184		
17				1808 - 2321		
18				1914 - 2457		
19				2020 - 2594		
20				2127 - 2731		
21				2233 - 2867		

Standards measurements in **bold type**

Maximum load-bearing capacity...

1.000 N 3.000 N 7.500 N 30.000 N

(insulators spacing)

...a complex and difficult problem influenced by factors such as (for example) skid height.

Increasing skid height reduces the load-bearing capacity as follows :

From 50 mm up : by 20 %
 From 80 mm up : by 30 %
 From 100 mm up : by 50 %

Coupler-connected pipes need (independent of weight) at least 3 rings per pipe length to relieve the couplers.

In the case of polyethylene pipes, the manufacturer's instructions on maximum support spacing **must** be observed.



CASING END SEALS



Brief descriptions of various types :



Type ON

(vulcanized, seamless moulded).

For a fixed combination of casing and carrier pipe diameters.



Type ONV

(vulcanized, seamless moulded)

For combining a constant casing pipe with variable carrier pipe diameters.



Type MN et MN 3

Made from one-piece cone shaped vulcanized sheet material, available in all pipe diameters.



Type MNO

From open rubber sheet material. Specially designed for existing installations. For all pipe diameters.



Société Internationale de Produits et Services Industriels

102 rue J.-B. Charcot
92400 Courbevoie - France

☎ : (33) 01 47 68 75 00
✉ : ipsi@ipsifrance.com

☎ : (33) 01 47 89 99 39
🌐 : www.ipsifrance.com

Casing end seal type ON (seamless)



Seamless, vulcanized sleeve for a **fixed combination** of casing/carrier pipe diameters. With one, two or three ribs to compensate for variable pipe sizes and alignment.

Additional security is ensured by rubber rimming on the sleeve's end. With 2 stainless steel clamps.

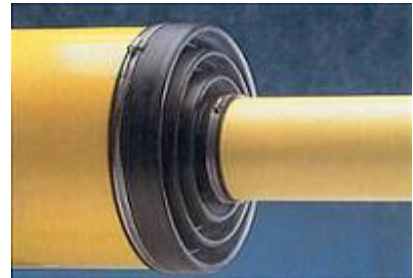
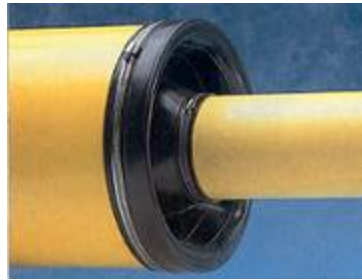

Type ON : assembly variations

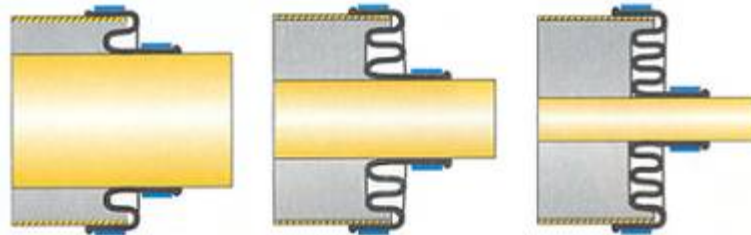

Casing end seal type ONV (seamless, variable)



Seamless, vulcanized sleeve for a constant casing pipe, but variable carrier pipe diameters. Adapts through the slicing off of cone tip as necessary. Saves storage space, since only one

sleeve is required for each respective casing size. Additional security ensured by rubber rimming on the sleeve's end. Inside features two O-rings for total sealing.



Because of its adaptability to varying assembly situations, model ONV is especially suited to situations involving shift caused by thermal expansion (e.g. heating lines).

Also available with apertures for additional pipes.

Type ONV : assembly variations

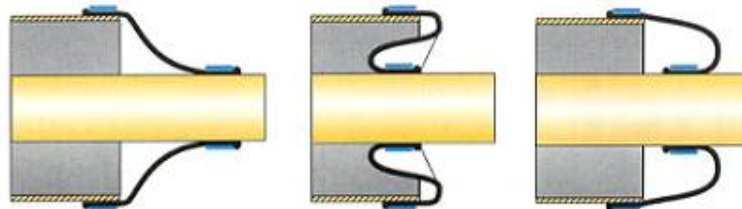

The assembly options using casing end seals MN, MN-3 and MNO are identical to those with type ONV.



**Casing end seal type MN
(with seam, 2 mm thick)**

**Casing end seal type MN 3
(with seam, 3 mm thick)**



Truncated cone in 2 or 3 mm thick, vulcanized sheet material. Available for all pipe combinations. Variations of assembly (see model ONV) make for an



especial suitability for situations involving thermal expansion (e.g. heating lines).



The model MN-3 (reinforced version) is available with apertures for additional pipes..

**Casing end seal type MNO
(with seam, open)**



An open sleeve for later additions to existing installations. Made from 2 mm thick rubber sheet material.



Bevelled edges create a larger contact area for bonding and make for a smooth join without an overlap.



Special versions

Please enquire about special combinations. We also supply casing end seals for multiple carrier pipes within one casing pipe.

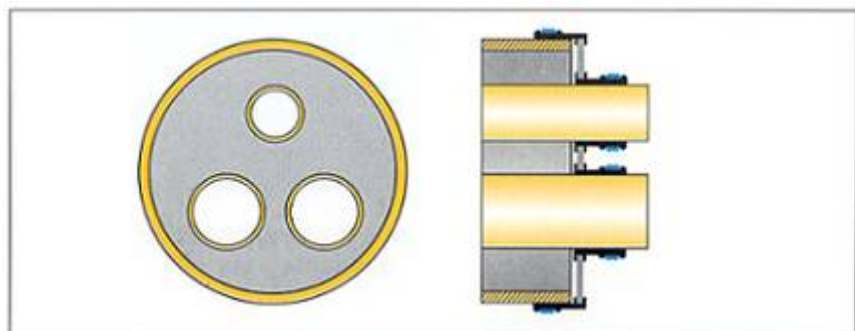

Société Internationale de Produits et Services Industriels

102 rue J.-B. Charcot

92400 Courbevoie - France

☎ : (33) 01 47 68 75 00

✉ : ipsi@ipsifrance.com

☎ : (33) 01 47 89 99 39

🌐 : www.ipsifrance.com

Material

on type ONV up to DN 125

- modified PVC.

on types ON and ONV from DN 150 upwards

- made from outstandingly long life EPDM rubber. Ideal for use underground.

on types MN, MN-3 and MNO

- made from CR rubber, which combines exceptional long life with a high resistance to the effects of oil. Ideal for underground use.

CR rubber is the best suited material for cold vulcanization - a strong and stable adhesion is guaranteed.

Size table for casing end seal, type ON

ID for casing pipe (mm)	Nominal diameter (inches)	ID for casing pipe (mm)	Nominal diameter (inches)
50 x 100	2 x 4	300 x 400	12 x 16
50 x 150	2 x 6	300 x 450	12 x 18
		300 x 500	12 x 20
65 x 150	2,5 x 6	300 x 550	12 x 22
80 x 150	3 x 6	350 x 450	14 x 18
80 x 200	3 x 8	350 x 500	14 x 20
80 x 250	3 x 10		
80 x 300	3 x 12	400 x 500	16 x 20
		400 x 550	16 x 22
100 x 150	4 x 6	400 x 600	16 x 24
100 x 200	4 x 8		
100 x 250	4 x 10	500 x 600	20 x 24
100 x 300	4 x 12	500 x 650	20 x 26
150 x 250	6 x 10	550 x 650	22 x 26
150 x 300	6 x 12		
150 x 350	6 x 14	600 x 750	24 x 30
150 x 400	6 x 16	600 x 800	24 x 32
200 x 250	8 x 10	650 x 750	26 x 30
200 x 300	8 x 12	650 x 800	26 x 32
200 x 350	8 x 14		
200 x 400	8 x 16	750 x 900	30 x 36
		800 x 950	32 x 38
250 x 300	10 x 12	800 x 1000	32 x 40
250 x 350	10 x 14		
250 x 400	10 x 16	850 x 1000	34 x 40
250 x 500	10 x 20		
250 x 550	10 x 22	900 x 1050	36 x 42

Size table for casing end Seal, type ONV

ID for casing pipe (mm)						
50	65	80	100	125	150	200
250	300	350	400	450	500	600

All casing end seals are delivered with stainless steel (VA) clamps for casing and carrier pipes.



Société Internationale de Produits et Services Industriels

102 rue J.-B. Charcot

92400 Courbevoie - France

☎ : (33) 01 47 68 75 00

✉ : ipsi@ipsifrance.com

☎ : (33) 01 47 89 99 39

🌐 : www.ipsifrance.com

MODULAR WALL AND CASING SEALS

(link seals)



In brief...

- Modular wall and casing seals guarantee an absolute air and water tight sealing of the annular space between carrier pipe and casing or between carrier pipe and wall aperture (i.e. wall sleeve).
- These interlocking modular seals are available in many sizes and have a very wide range of applications.

The system in its range and flexibility constitutes the ideal solution for nearly all applications.

It offers :

- quick and simple installation for all kinds of pipeline,
- positive hydrostatic sealing up to 2 bar,
- electrical insulation between the pipes (cathodic protection),
- absorption of vibrations, shocks and sounds,
- it complies with standards for conveying drinking water issued by the German Ministry of Health,
- it increases the stability and the support of the carrier pipe.



Société Internationale de Produits et Services Industriels

102 rue J.-B. Charcot

92400 Courbevoie - France

☎ : (33) 01 47 68 75 00

✉ : ipsi@ipsifrance.com

☎ : (33) 01 47 89 99 39

🌐 : www.ipsifrance.com

Characteristics

Modular seals developed from a well-known and acclaimed basic system of link sealing, improving it substantially in many ways.

The improvements carried out to the material and the construction guarantees you an absolutely reliable seal for wall penetrations in almost any context and in long life durability.

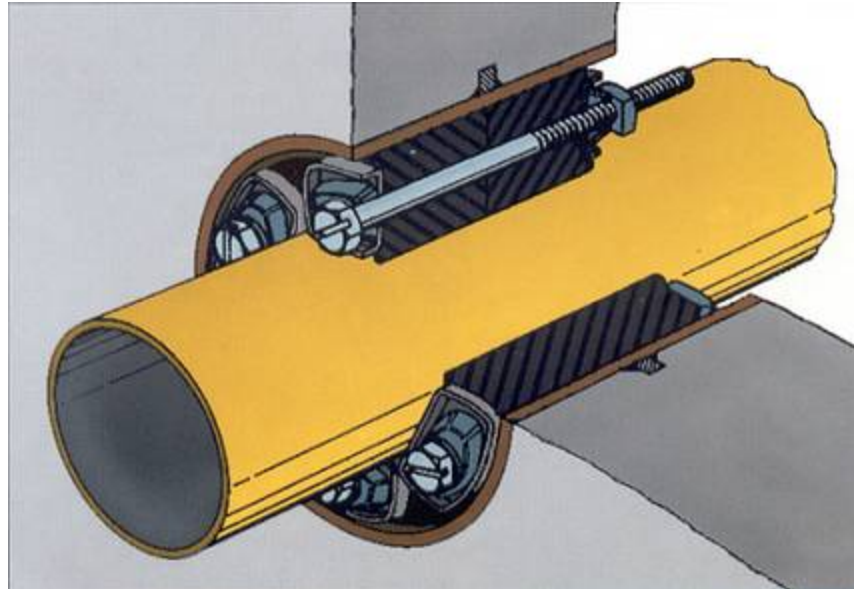

Hydrostatic sealing up to 2 bar :

if the gasket has been correctly fitted to the wall opening to prevent any ejection, pressures up to 6 bar can be reached.

Temperature resistance :

The modular seals take continuous temperature up to 80°C, and short term peaks up to 110°C.

Cathodic protection :

Each metal part is plastic coated and is free from any contact with the pipe. The raised surrounds on the plastic pressure plates provide a larger spark gap, considerably improving the cathodic protection

Drinking water authorization :

The link seals are fully conformed with the specifications relating to drinking water required by the German Ministry of Health.

Shocks and vibrations absorption:

Due to their construction, modular seals are more stable, absorb shocks and vibrations (from changes in internal pipe pressure or ground disturbances) and dampen sounds.



Société Internationale de Produits et Services Industriels

102 rue J.-B. Charcot

92400 Courbevoie - France

☎ : (33) 01 47 68 75 00

✉ : ipsi@ipsifrance.com

☎ : (33) 01 47 89 99 39

🌐 : www.ipsifrance.com

Innovative details make for optimum sealing

Non toxicity and oil resistance :
the sealing elements are made of thermo-plastic elastomer on nitrile rubber-PVC base.

Unthreaded bolt head : no sharp thread edges to slice into the sealing elements during extreme tightening... Thereafter reduced abrasion.

Plastic pressure plates, steel pressure plates : identically moulded contours : preventing plastic cradage and allowing sironger tightening.

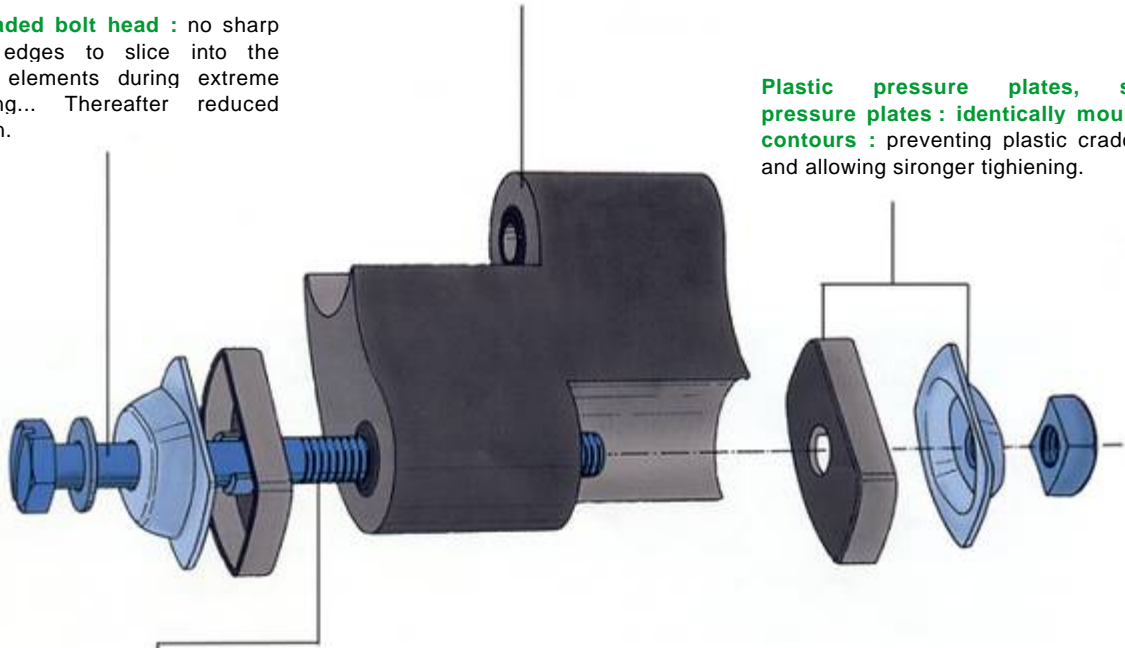

Thread in stainless steel version is lubricant coated : prevents reciprocal abrasion, renders the use of water-pollutive greases unnecessary.

Improved cathodic protection : raised surround on plastic pressure plate lengthens spark gap.

Bolts and nuts comply with DIN standards :
no problem about spare parts.

Anti-corrosion measures improved :
all metal parts in galvanized yellow chromium-plated steel.

Simple to handle, quick to install

...thanks to their modular structure.

Modular seals are delivered preassembled to the specified link number - by adding or removing the sealing elements, you can quickly

adapt the ring to other pipe diameter, **reducing the necessary stock of different sizes to a minimum.**



Hexagonal socket head bolts facilitate the assembly of small seal-rings



Thanks to the special construction of the pressure plates, the nuts can not be distorted.



Société Internationale de Produits et Services Industriels

102 rue J.-B. Charcot
92400 Courbevoie - France
☎ : (33) 01 47 68 75 00
✉ : ipsi@ipsifrance.com

☎ : (33) 01 47 89 99 39
🌐 : www.ipsifrance.com

Options

Modular seals are available in 2 oil-resistant and drinking water compatible versions :

Model SV :

All metal parts are made of galvanized, yellow chromium-plated steel.

Model VA :

All metal parts are made of stainless steel V4a. (material nr. 1.4571).

Sizes

Twenty-one different sizes cope flawlessly with all dimensions of annular space, even smallest widths which previously could not be sealed sufficiently, if at all.

Model	Sealing range in mm	Arc length	Installation length	Minimum Wall thickness	Bolts	Spanner size	Weight/ piece (kg)
DG 200	12,5 - 16	30,5	64	50	M 5 x 60	4 Allen key	0,04
DG 250	15,5 - 20	28,8	64	50	M 5 x 60	4 Allen key	0,04
DG 300	17,0 - 23	40,3	90	70	M 8 x 85	6 Allen key	0,10
DG 315	20,5 - 27	37,7	90	70	M 8 x 85	6 Allen key	0,11
DG 325	24,5 - 33	77,0	101	70	M 8 x 95	13 HEX.	0,25
DG 350	24,5 - 33	41,9	101	70	M 8 x 95	13 HEX.	0,16
DG 375	31,5 - 40	55,5	101	70	M 8 x 95	13 HEX.	0,23
DG 465	31,5 - 40	93,0	136	100	M 10 x 130	13 HEX.	0,52
DG 400	36,5 - 46	93,0	136	100	M 10 x 130	13 HEX.	0,60
DG 415	36,5 - 46	68,0	136	100	M 10 x 130	16 HEX.	0,46
DG 425	28,5 - 38	93,0	136	100	M 10 x 130	17 HEX.	0,48
DG 450	40,5 - 51	92,0	136	100	M 10 x 130	17 HEX.	0,66
DG 475	40,5 - 51	68,0	136	100	M 10 x 130	17 HEX.	0,52
DG 500	58,5 - 72	99,0	151	110	M 12 x 140	19 HEX.	1,07
DG 565	58,5 - 72	78,5	151	110	M 12 x 140	19 HEX.	0,85
DG 525	48,5 - 60	99,0	151	110	M 12 x 140	19 HEX.	0,96
DG 550	48,5 - 60	78,5	151	110	M 12 x 140	19 HEX.	0,76
DG 600	81,0 - 100	101,0	151	110	M 12 x 140	19 HEX.	1,54
DG 650	70,5 - 84	104,0	151	110	M 12 x 140	19 HEX.	1,43
DG 800	128 - 145	167,5	151	110	M 12 x 140	19 HEX.	-
DG 865	143 - 165	167,5	151	110	M 12 x 140	19 HEX.	-

Important

Models with similar sealing range are available in differing arc lengths. If other considerations do not play a role, use the greater arc length for larger pipe diameters to reduce link numbers and assembly time.

For exact calculations regarding the number and model of links required, use our floppy disc.

If you need information about our sleeves for wall apertures consult our "Wall sleeves" leaflet.



Société Internationale de Produits et Services Industriels

102 rue J.-B. Charcot

92400 Courbevoie - France

☎ : (33) 01 47 68 75 00

✉ : ipsi@ipsifrance.com

☎ : (33) 01 47 89 99 39

🌐 : www.ipsifrance.com

WALL SLEEVES



In brief...

- Wall sleeves of fibre-cement or steel are concreted into building constructions at those points in the wall-work where pipes will later go through.

Assembly notice :

Use only our modular seals to ensure absolute sealing of the space between sleeved wall opening and pipe (annulus) - details in our modular seals leaflet.



Société Internationale de Produits et Services Industriels

102 rue J.-B. Charcot
92400 Courbevoie - France
☎ : (33) 01 47 68 75 00
✉ : ipsi@ipsifrance.com

☎ : (33) 01 47 89 99 39
🌐 : www.ipsifrance.com

Fibre-cement wall sleeves

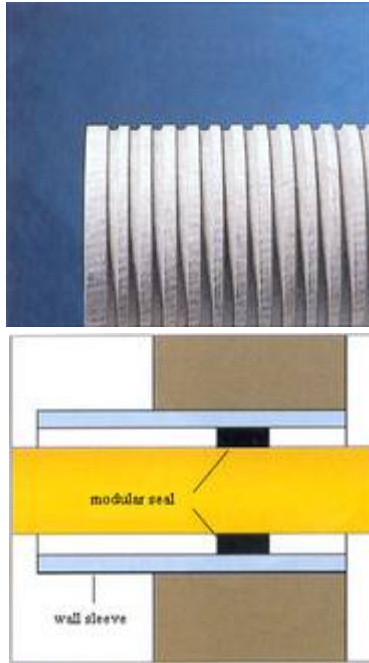

Fibre-cement wall sleeves are excellent for use with concrete. Their grooved exterior surface and homogenous material ensures the total join.

Fibre-cement wall sleeves are competitively priced and offer substantial advantages such as :

- the same thermal expansion coefficient as concrete,
- no corrosion,
- the possibility of adjustment after installation,
- its projection beyond the wall vertical if wished (whereby the modular seal ring must be seated inside the actual wall thickness - see diagram),
- its use as a formwork for making round wall openings.

Steel wall sleeves



Steel wall sleeves are fitted with an anchoring collar **welded on right round and on both sides** (see diagram).

This bilaterally-joined anchor guarantees not only a firm fit in the wall but also presents an absolutely watertight barrier.

Steel wall sleeves are available with collars of different sizes and forms, and (depending on requirements) with or without :

- protection against corrosion,
- undercoating,
- galvanization.

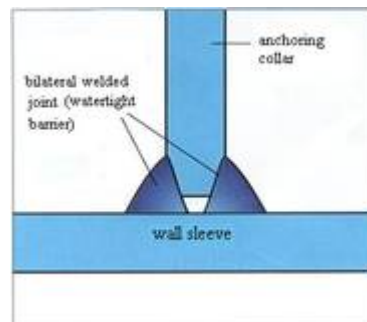

Société Internationale de Produits et Services Industriels

102 rue J.-B. Charcot

92400 Courbevoie - France

☎ : (33) 01 47 68 75 00

✉ : ipsi@ipsifrance.com

☎ : (33) 01 47 89 99 39

🌐 : www.ipsifrance.com

Steel wall sleeves – special constructions

Our steel wall sleeves range includes many special constructions for differing applications :

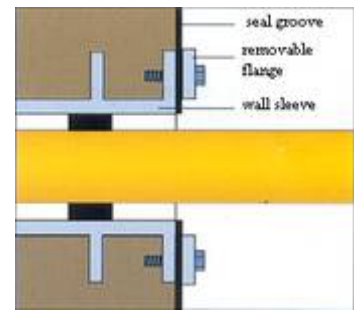

Sleeves with removable flanges provide a perfect water sealing when installed in seal grooves.

- with welded or removable anchoring collar, for fitting into a seal groove, (see drawing above),
- with several anchoring collars,

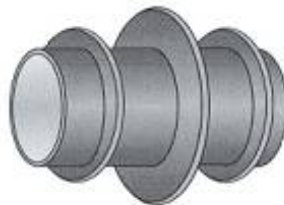

- with anchoring collars of various forms and sizes,

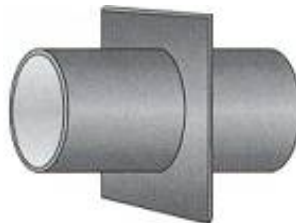

- with one or two anchoring collars to fit flush with the wall,

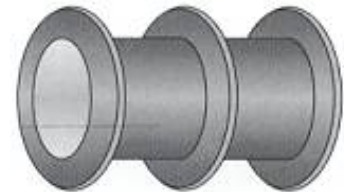

- All special constructions are also available as wall sleeve bundles.



Wall sleeves in VA stainless steel



V2A and V4A sleeves are entirely corrosion resistant. The VA stainless steel has about twice the strength of normal steel.

Hence VA steel sleeves are half the thickness of that laid down by DIN 2458; with no reduction in their stability.

Security notice

Do not use any smooth plastic pipe sections as substitute for wall sleeves !

A positive watertight sealing can not be achieved without taking additional measures.

Because of differences in thermal coefficients of expansion between plastic and concrete and because of heat emission during concrete setting, plastic pipe sections can not be cemented in to achieve a watertight fit.



Société Internationale de Produits et Services Industriels

102 rue J.-B. Charcot

92400 Courbevoie - France

☎ : (33) 01 47 68 75 00

✉ : ipsi@ipsifrance.com

☎ : (33) 01 47 89 99 39

🌐 : www.ipsifrance.com

Products available

Fibre-cement sleeves

inside Ø	outside Ø (approx.)	max. length available (mm)	
80 mm	104 mm	1000	from stock, in all lengths available (also oblique cut).
100 mm	124 mm	1250	
125 mm	151 mm	1000	
150 mm	178 mm	1250	
200 mm	234 mm	1250	
250 mm	286 mm	1250	
300 mm	342 mm	1250	
350 mm	388 mm	1250	
400 mm	442 mm	1250	
450 mm	495 mm	1250	
500 mm	550 mm	1250	
600 mm	660 mm	1250	
700 mm	775 mm	1000	
800 mm	890 mm	1000	
900 mm	1000 mm	1000	
1000 mm	1120 mm	1000	
1100 mm	1220 mm	1000	no stock - delivery time on request.
1200 mm	1320 mm	1000	
1300 mm	1420 mm	1000	

Dimensions and technical data according to DIN 19840 and 19850.

Steel wall sleeves

Available in accordance with DIN 2458 (normal wall thickness) in all diameters, all lengths.

Delivery time depending on the option : 1 to 2 weeks.

VA steel wall sleeves

Available according to DIN 2463 and in the dimensions set up by the cellulose industry. For the latter : DN = inside diameter of the pipe.

Available in all diameters and all lengths.

Wall thickness = 50% of the normal wall thickness (DIN 2458). Delivery time, depending on variation required : 1 to 2 weeks.



Société Internationale de Produits et Services Industriels

102 rue J.-B. Charcot

92400 Courbevoie - France

☎ : (33) 01 47 68 75 00

✉ : ipsi@ipsifrance.com

☎ : (33) 01 47 89 99 39

🌐 : www.ipsifrance.com

PIPELINE

PIGS



Société Internationale de Produits et Services Industriels

102 rue J.-B. Charcot
92400 Courbevoie - France

☎ : (33) 01 47 68 75 00
✉ : ipsi@ipsifrance.com

☎ : (33) 01 47 89 99 39
🌐 : www.ipsifrance.com

FOAM PIGS



PRESENTATION

Foam pigs are used during commissioning, start-up and exploitation of oil, gas or water pipelines, and particularly during the following operations :

- product filling-in,
- water filling-in for hydrostatic test,
- emptying, dewatering, swabbing, drying and cleaning,
- batching.

These Foam pigs have been designed to maintain a very effective real.

MANUFACTURING

The IPSI foam pigs are manufactured with selected quality of intercommunicating polyurethane foam having a good wear and aggressive agent resistances (acids, aromatics, etc...)

They all have a thick polyurethane elastome disc at one end.

When coated, this one is made with polyurethane elastomer.

Nose chamfered.



Société Internationale de Produits et Services Industriels

102 rue J.-B. Charcot
92400 Courbevoie - France

☎ : (33) 01 47 68 75 00
✉ : ipsi@ipsifrance.com

☎ : (33) 01 47 89 99 39
🌐 : www.ipsifrance.com

Standard models

The standard models, shown hereafter, are available within a short period of time up to 64" nominal diameter.

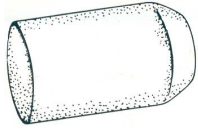

- Body foam density 25 kg/m³.
- One end coated.
- Bare foam on the body.

PU – PLAIN

PU – PLAIN S

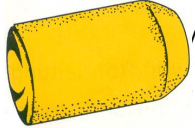

- foam density 110 – 115 kg/m³.
- end coated.
- foam on the body.

- Same as PU – PLAIN except for foam density 80 – 85 kg/m³.

PU – LR

PU – LR S



- foam density 110 – 115 kg/m³.
- coated body.

- Same as PU – LR type except for foam density 80 – 85 kg/m³.

PU – CC

PU – CC S

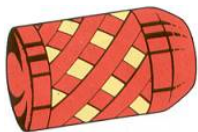

- foam density 110 – 115 kg/m³.
- and end fully coated.
- the spiral coating on the body.

- Same as PU – CC type except for foam density 80 – 85 kg/m³.

PU – AC

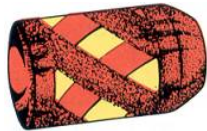

- Body foam density 110 – 115 kg/m³.
- One spiral in carborandum.
- One opposite spiral in elastomer P.U.
- Nose and end fully coated.

PU – WB



- Body foam density 110 – 115 kg/m³.
- Wire brush spiral alternated with elastomer P.U. spiral.
- Nose and end fully coated.

OPTIONS :

- Pulling rope.
- Both ends Chamfered.
- Internal cavity for pig transmitter detector.
- PU - PLAIN and PU-PLAIN S type nose coating.



Société Internationale de Produits et Services Industriels

102 rue J.-B. Charcot

92400 Courbevoie - France

☎ : (33) 01 47 68 75 00

✉ : ipsi@ipsifrance.com

☎ : (33) 01 47 89 99 39

🌐 : www.ipsifrance.com

SPHERES

SOLID : 1" thro 8" / INFLATABLE : 3" thro 36"

SPECIFICATION

- Thick walled polyurethane elastomer.
- Seamless construction.
- Constant wall thickness.
- Available in hardness range of between 50° and 80° shore A.
- All polyurethane mouldings are manufactured in-house to strict quality standards and have exceptionally good physical and chemical-resistant properties.
- 3" thro 14" have single Schrader type valve.
- 16" thro 36" have two large bore Schrader type valves.
- Valves protected with hexagon headed brass sealing plugs.

ACCESSORIES

- Valve cap removal tool, valve core removal tool, filling connector, diameter calibrated sizing tape, sizing ring, hand operated sphere lifter, hand operated inflation pump.

METER PROVER QUALITY SPHERES AVAILABLE.

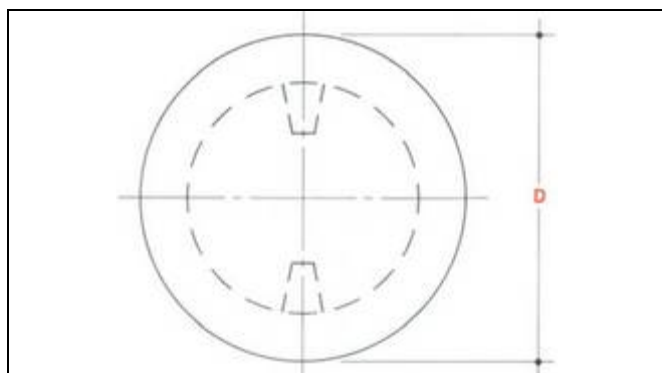
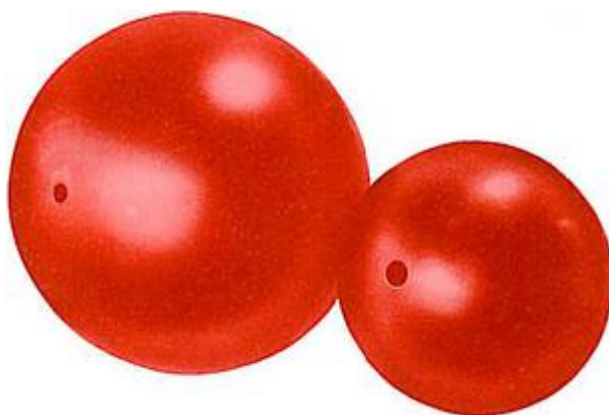

Solid Spheres

Pipe size	Diameter 'D' (mm)	Pipe size	Diameter 'D' (mm)
1½"	39,0	4"	103,0
2"	51,5	6"	158,0
3"	78,0	8"	209,0

Inflatable Spheres

Pipe size	Uninflated diameter 'D' (mm)	Pipe size	Uninflated diameter 'D' (mm)
3"	75,0	20"	485,0
4"	101,0	22"	536,0
6"	150,0	24"	583,0
8"	201,0	26"	633,0
10"	252,0	28"	683,0
12"	304,0	30"	733,0
14"	333,0	32"	784,0
16"	384,0	34"	835,0
18"	435,0	36"	883,0

Dimensions in millimetres

PRODUCT GUIDE

- Spheres are extremely versatile pipeline tools.
- For product separation batching and swabbing.
- Capable of evacuating liquids from pipelines.
- Will remove condensate from natural gas pipelines.
- Suitable for hydrostatic testing applications.
- Sphere operates bi-directionally.
- Suitable for automated separation and batching operations.
- Ideal for a meter prover mechanically-defined interface.
- Sphere flow tees should be fitted when side branch is greater than 25 per cent of line size.



Société Internationale de Produits et Services Industriels

102 rue J.-B. Charcot

92400 Courbevoie - France

☎ : (33) 01 47 68 75 00

✉ : ipsi@ipsifrance.com

☎ : (33) 01 47 89 99 39

🌐 : www.ipsifrance.com

PRODUCT SPECIFICATION

INFLATABLE PIPELINE SPHERES

Inflatable pipeline spheres are manufactured from a high performance polyurethane elastomer from specially designed tooling which enables production of monolithic (seamless) thick wall spheres.

Smaller sizes of spheres, 3" up to and including 14" are fitted with a single spring loaded inflation valve.

Larger sizes, 16" up to and including 36" are manufactured with two valves positioned diametrically opposite. A valve sealing cap protects the valve from damage and ingress of dirt and prevents the inflation of the sphere caused by high pipeline operating pressure. The hexagonal head of the sealing cap may be easily marked for identification purposes.

The following accessories are required for sizing and inflation of spheres.

Multi-functional inflation unit : This unit incorporates a sealing plug removal socket, fill tube and schrader valve removal Tool.

Pressure pump : Hand operated with reservoir.
Pressure capability ; up to 15 BAR
Delivery : 250 - 300 cc per stroke.

NOTE : It is important that spheres are run on pipelines which have been designed and built for sphere operations.

The method of manufacture ensures that the sphere has a constant wall thickness and therefore remains rounder much longer, as the sphere does eventually wear through use.

Material Characteristics

Polyester based polyurethane elastomer.

Physical properties :

Hardness	70 - 75 shore A
Tensile	30 - 33 MN/m
300 % Modulus	7 – 8,5 MN/m
Tear Strength	70 KN/m
Elongation	600 %

Storage and Operating Conditions

Environmental temperature for :

Storage empty spheres : minus 40 degrees C to plus 50 degrees C.
Recommended operating temps : minus 5 degrees C to plus 75 degrees C.

Polyurethane must be handled carefully at minus 40 degrees C.
Before it is inserted into the meter prover, the sphere should be slowly brought up to temperature to avoid sudden temperature shocks.

Excessive temperature and humidity combined, causes deterioration of the sphere material. For long periods of time, spheres should be stored in an area away from direct sunlight, with fairly low humidities.

HIGH TEMPERATURE SPHERES ALSO AVAILABLE



Société Internationale de Produits et Services Industriels
102 rue J.-B. Charcot
92400 Courbevoie - France
☎ : (33) 01 47 68 75 00
✉ : ipsi@ipsifrance.com
☎ : (33) 01 47 89 99 39
🌐 : www.ipsifrance.com

GAUGING / COMMISSIONING

IP.SG2 - 2" thro 14" GAUGING PIG

SPECIFICATION

- Two polyurethane driving cups.
- Polyurethane protector nose.
- Polyurethane mouldings are manufactured in-house to strict quality standards and have exceptionally good physical and chemical-resistant properties.
- Pig is fitted with gauging plate machined to client's order normally 90% to 95% of line bore. Gauging plate may be either carbon steel or aluminium alloy.
- Sizes 1" thro 6" will traverse bends to 3D radius.
- Sizes 8" thro 14" will traverse bends to 1½D radius.
- Traverses full bore ball and conduit valves.
- Traverses barred tees to full branch size.
- Carbon steel body components have two coats of chemical-resistant anti-corrosive paint.

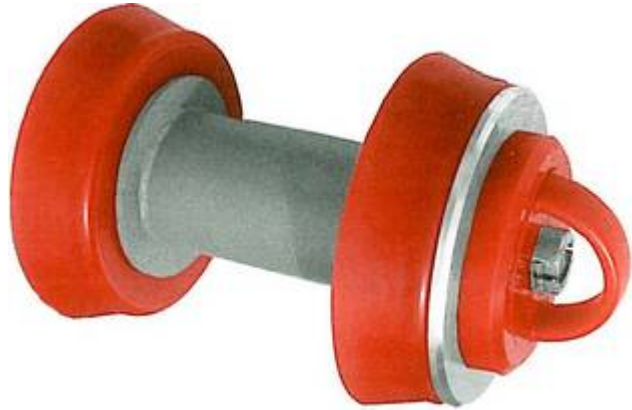

PRODUCT GUIDE

- Pre-commissioning duties.
- Gauging pig is used for proving roundness of constructor's pipe, for removing construction debris and for identifying excessive weld penetration.
- A classic design which has been specified for many years by pipeline operators.

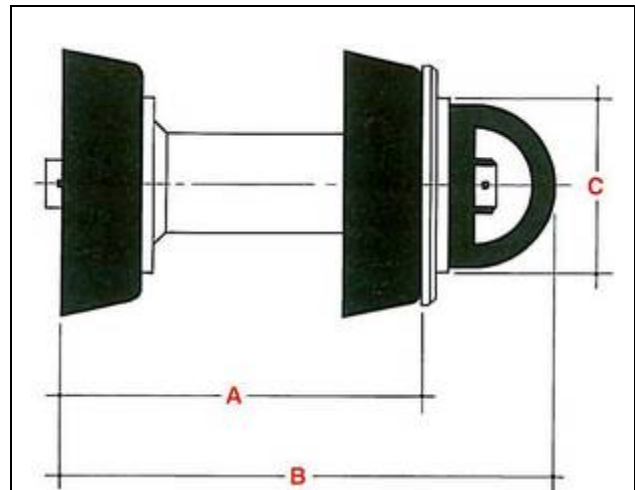

General dimensions

Size	A	B	C
2"	75	125	35
3"	110	160	50
4"	140	200	70
6"	220	280	110
8"	275	375	140
10"	350	450	180
12"	400	500	220
14"	450	550	250

Dimensions in millimetres



Société Internationale de Produits et Services Industriels

102 rue J.-B. Charcot

92400 Courbevoie - France

☎ : (33) 01 47 68 75 00

✉ : ipsi@ipsifrance.com

☎ : (33) 01 47 89 99 39

🌐 : www.ipsifrance.com

GAUGING / COMMISSIONING

IP.LG2 16" thro 48" GAUGING PIG

SPECIFICATION

- Two polyurethane driving cups.
- Polyurethane protector nose.
- Polyurethane mouldings are manufactured in-house to strict quality standards and have exceptionally good physical and chemical-resistant properties.
- Pig is fitted with gauging plate machined to client's order - normally 90% to 95% of line bore. Gauging plate may be either carbon steel or aluminium alloy.
- Will traverse bends down to 1½D radius.
- Traverses full bore ball and conduit valves.
- Traverses barred tees to full branch size.
- Carbon steel body components have two coats of chemical-resistant anti-corrosive paint.

PRODUCT GUIDE

- Pre-commissioning duties.
- Gauging pig is used for proving roundness of constructor's pipe, for removing construction debris and for identifying excessive weld penetration.
- A classic design which has been specified for many years by pipeline operators.
- Constructed from prime steel materials with driving cups manufactured from polyurethane having exceptionally good physical and chemical resistant properties.

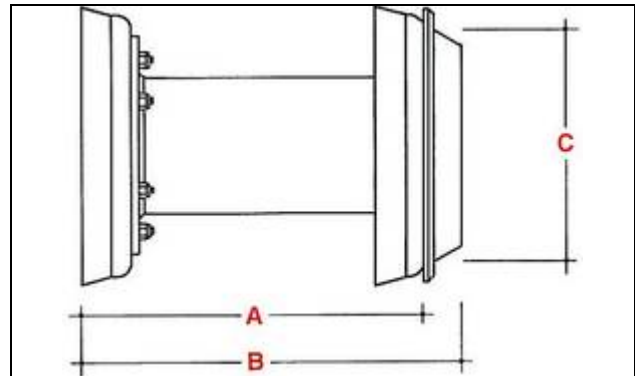
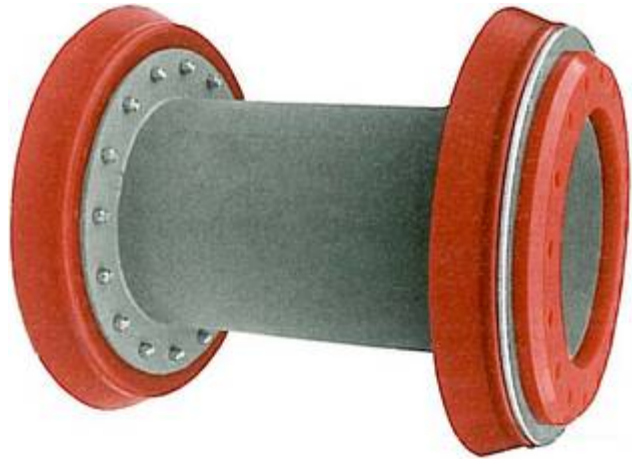

General dimensions

Taille	A	B	C
16"	500	535	320
18"	575	610	360
20"	625	660	400
22"	675	710	445
24"	725	775	500
26"	750	800	540
28"	800	850	590
30"	850	900	630
32"	900	950	670
34"	950	1000	720
36"	1000	1050	760
38"	1100	1160	810
40"	1200	1260	860
42"	1300	1360	900
48"	1400	1460	1060

Dimensions in millimetres



SEPARATION / BATCHING

SPECIFICATION

- Four polyurethane driving cups.
- Polyurethane protector nose.
- All polyurethane components are manufactured in-house to strict quality standards and have exceptionally good physical and chemical-resistant properties.
- Sizes 2" thro 8" will traverse bends to 3D radius.
- Sizes 10" thro 14" will traverse bends to 1½D radius.
- Traverses full bore ball, conduit and wedge gate valves.
- Traverses barred tees up to full branch size.
- Carbon steel body components have two coats of chemical-resistant, anti-corrosive paint.



IP.SS.90-4 2" thro 14"
SEPARATION / BATCHING PIG

PRODUCT GUIDE

- For product separation, batching, displacement, swabbing and line clearance duties.
- Can be used for gauging when fitted with an optional gauging plate.
- Suitable for hydrostatic testing applications.
- Ruggedly constructed from prime steel materials with driving cups manufactured from polyurethane having exceptionally good physical and chemical resistant properties.

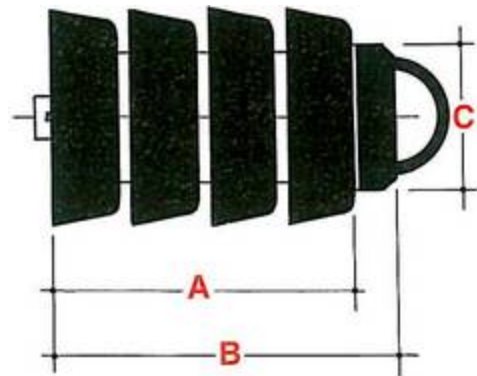

General dimensions

Size	A	B	C
2"	110	115	30
3"	135	140	45
4"	175	200	65
6"	230	255	100
8"	280	310	135
10"	350	385	170
12"	400	430	215
14"	450	495	245

Dimensions in millimetres



Société Internationale de Produits et Services Industriels

102 rue J.-B. Charcot

92400 Courbevoie - France

☎ : (33) 01 47 68 75 00

✉ : ipsi@ipsifrance.com

☎ : (33) 01 47 89 99 39

🌐 : www.ipsifrance.com

SEPARATION / BATCHING

IP.LS.90-4 16" thro 48" SEPARATION / BATCHING PIG



SPECIFICATION

- Four polyurethane driving cups.
- Polyurethane protector nose.
- All polyurethane components are manufactured in-house to strict quality standards and have exceptionally good physical and chemical-resistant properties.
- Will traverse bends down to 1½D radius.
- Traverses full bore ball, conduit and wedge gate valves.
- Traverses barred tees up to full branch size.
- Carbon steel body components have two coats of chemical-resistant, anti-corrosive paint.

PRODUCT GUIDE

- For product separation, batching, displacement, swabbing and line clearance duties.
- Can be used for gauging when fitted with an optional gauging plate.
- Suitable for hydrostatic testing applications.
- Ruggedly constructed from prime steel materials with driving cups manufactured from polyurethane having exceptionally good physical and chemical resistant properties.

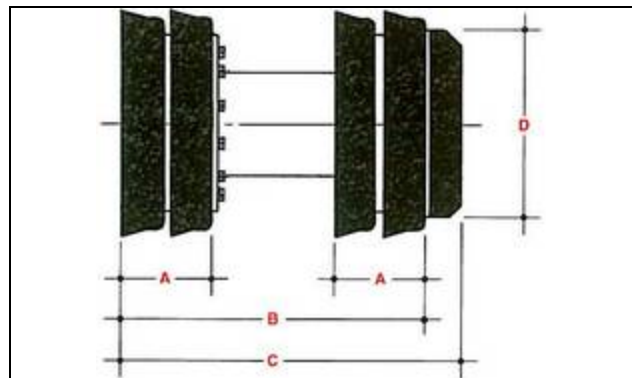

General dimensions

Size	A	B	C	D
16"	165	550	580	320
18"	165	600	635	360
20"	185	650	685	400
22"	185	700	735	445
24"	195	750	800	500
26"	195	800	850	540
28"	200	850	900	590
30"	200	900	950	630
32"	200	950	1000	670
34"	230	1000	1050	720
36"	230	1100	1150	760
38"	230	1200	1260	810
40"	260	1300	1360	860
42"	260	1400	1460	900
48"	260	1500	1560	1060

Dimensions in millimetres



Société Internationale de Produits et Services Industriels

102 rue J.-B. Charcot
92400 Courbevoie - France

☎ : (33) 01 47 68 75 00
✉ : ipsi@ipsifrance.com

☎ : (33) 01 47 89 99 39
🌐 : www.ipsifrance.com

CLEANING

SPECIFICATION

- Two polyurethane driving cups of long lipped design ensure efficient sealing and long run performance.
- Polyurethane protector nose.
- Two circular stainless steel trim brush units giving positive 360° pipe coverage.
- Sizes 3" thro 6" will traverse bends to 3D radius.
- Sizes 8" thro 18" will traverse bends to 1½D radius.
- Traverses full opening ball, through conduit and wedge gate valves.
- Traverses standard swing check valves.
- Traverses side branches where the branch diameter is less than 70 per cent of the line diameter. Side branches which are greater than 70 per cent of the line diameter should have guide bars fitted.
- Carbon steel body components have two coats of chemical-resistant anti-corrosive paint.

IP.RCN 3" - 18" CLEANING PIG

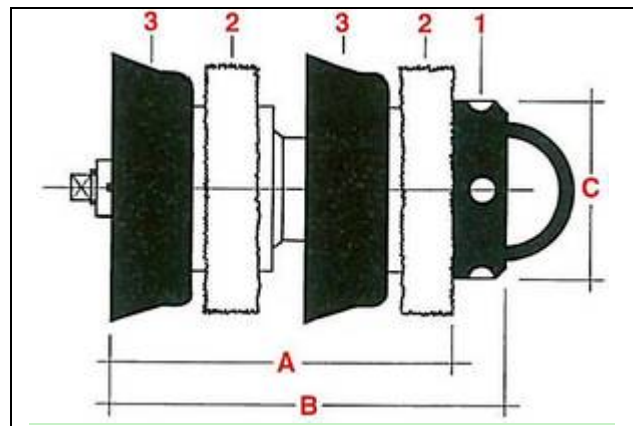

Spare Parts

Part	Description
1	Protector nose
2	Brush unit
3	Driving cup

General Dimensions

Size	A	B	C
3"	90	115	50
4"	115	140	70
6"	175	205	110
8"	225	255	140
10"	250	285	180
12"	275	310	220
14"	325	360	250
16"	375	410	320
18"	445	480	360

Dimensions in millimetres

PRODUCT GUIDE

- General purpose cleaning pig.
- Ideal for removal of loose rust and mill scale from refinery, oil, gas and process plant pipework.
- Suitable for pre-commissioning and on-stream cleaning duties.
- Adequate by-pass facilities are built into the basic pig to allow velocity control and to increase cleaning efficiency.
- Long trim stainless steel brushes make this pig suitable for both short and medium length pipeline systems.



Société Internationale de Produits et Services Industriels
 102 rue J.-B. Charcot
 92400 Courbevoie - France
 ☎ : (33) 01 47 68 75 00
 ✉ : ipsi@ipsifrance.com
 ☎ : (33) 01 47 89 99 39
 🌐 : www.ipsifrance.com

CLEANING

IP.UG1 - 12" thro 36" CLEANING PIG

SPECIFICATION

- Short-bodied 2 cup design allows bends down to 1½D radius to be negotiated.
- Two polyurethane driving cups of long-lipped design ensure efficient sealing and long run performance.
- Polyurethane protector nose.
- Polyurethane mouldings are manufactured in-house to strict quality standards and have exceptionally good physical and chemical-resistant properties.
- High wear and abrasion resistance.
- Stainless steel brush units mounted on spring steel arms give 360° pipe coverage.
- Polyurethane plough blades optional to brushes.
- By-pass facility.
- Will traverse full bore ball and conduit valves and side branches provided guide bars are fitted.
- Carbon steel body components have two coats of chemical-resistant anti-corrosive paint.

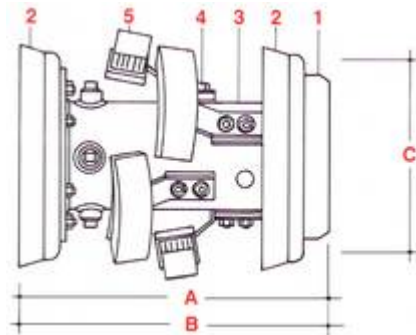
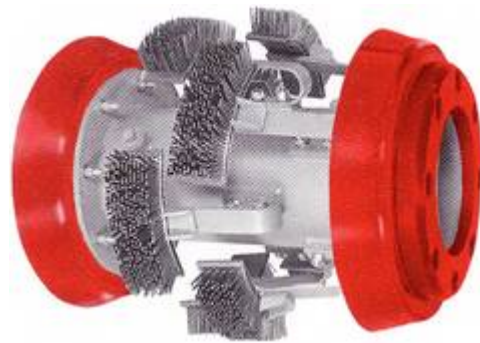

PRODUCT GUIDE

- General purpose cleaning pig suitable for travelling through long distance cross country pipelines.
- May be used for pre-commissioning and on-stream cleaning duties.
- For removal of loose rust and mill scale from new pipelines.
- Ideal for use in crude oil lines when fitted with either stainless steel trim brushes or polyurethane ploughs for removal of paraffin or sand deposits.
- Considerable improvements in (he efficiency of gas pipelines are achieved by conditioning the pipe by regular running of this type of pig.
- A classic design which has been specified for many years by pipeline operators.

Spare Parts

Part	Description	Part	Description
1	Protector nose	4	Guide
2	Driving cup	5	Brush unit/ Plough blade
3	spring arm		

General dimensions

Size	A	B	C
12"	450	485	220
14"	450	485	250
16"	550	585	320
18"	600	635	360
20"	650	685	400
22"	700	735	445
24"	800	850	500
26"	850	900	540
28"	900	950	590
30"	950	1000	630
32"	1000	1050	670
34"	1050	1100	720
36"	1100	1150	760

Dimensions in millimetres



CLEANING

SPECIFICATION

- Short-bodied 3 cup design allows negotiation of bends down to 1 ½D radius.
- Three polyurethane driving cups of long-lipped design ensure efficient sealing and long run performance.
- Polyurethane protector nose.
- Polyurethane mouldings are manufactured in-house to strict quality standards and have exceptionally, good physical and chemical-resistant properties.
- High wear and abrasion resistance.
- Stainless steel brush units mounted on spring steel arms give 360° pipe coverage.
- Polyurethane plough blades optional to brushes.
- By-pass facility.
- Will traverse full bore ball and conduit valves and side branches provided guide bars are fitted.
- Carbon steel body components have two coats of chemical-resistant anti-corrosive paint.



IP.UG2 - 16" thro 48" CLEANING PIG

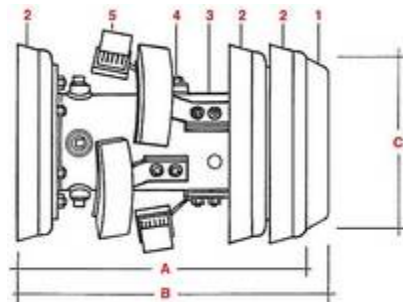

Spare Parts

Part	Description	Part	Description
1	Protector nose	4	Guide
2	Driving cup	5	Brush unit/ plough blade
3	Spring arm		

General dimensions

Size	A	B	C
16"	650	680	335
18"	700	730	360
20"	750	780	400
24"	900	930	500
26"	950	980	545
28"	1000	1030	590
30"	1050	1100	630
32"	1100	1150	670
34"	1150	1200	720
36"	1200	1250	770
38"	1250	1310	810
40"	1300	1360	860
42"	1350	1410	900
48"	1550	1660	1060

Dimensions in millimetres

PRODUCT GUIDE

- General purpose cleaning pig suitable for travelling through long distance cross country pipelines.
- Three cup design giving enhanced front end stability.
- May be used for pre-commissioning and on-stream cleaning duties.
- Ideal for removal of loose rust and mill scale from new pipelines.
- Ideal for use in crude oil lines when fitted with either stainless steel trim brushes or polyurethane ploughs for removal of paraffin or sand deposits.
- Considerable improvements in the efficiency of gas pipelines are achieved by conditioning the pipe by regular running of this type of pig.
- A classic design which has been specified for many years by pipeline operators.
- We have improved this pig by fitting a protector nose.



Société Internationale de Produits et Services Industriels
 102 rue J.-B. Charcot
 92400 Courbevoie - France
 ☎ : (33) 01 47 68 75 00
 ✉ : ipsi@ipsifrance.com
 📞 : (33) 01 47 89 99 39
 🌐 : www.ipsifrance.com

CLEANING



IP.K3 CLEANING PIG

SPECIFICATION

- Four polyurethane driving cups.
- Polyurethane protector nose.
- Polyurethane mouldings are manufactured in-house to strict quality standards and have exceptionally good physical and chemical-resistant properties.
- Stainless steel trim brush units mounted on spring steel arms give 360° pipe coverage.
- Polyurethane plough blades optional to brushes.
- By-pass facility to special order.
- 6" and 8" sizes will traverse bends to 3D radius.
- 10" and 12" sizes will traverse bends down to 1½D radius.
- Carbon steel body components have two coats of chemical-resistant anti-corrosive paint.

PRODUCT GUIDE

- Pre-commissioning and on-stream cleaning and scraping duties.
- Four cup long bodied design, articulated to facilitate safe passage through full bore side branches ball and conduit valves.
- Ideal for removal of loose rust and mill scale from new pipelines.
- Ideal for use in crude oil pipelines for the removal of paraffin or sand deposits when fitted with either stainless steel trim brushes or polyurethane plough blades.
- Considerable improvements in the efficiency of gas pipelines are achieved by conditioning the pipe by regular running of this type of pig.
- A classic design of pig specified by pipeline operators over many years.

Spare Parts

Part	Description
1	Protector nose
2	Driving cup
3	spring arm
4	Guide
5	Brush unit / plough blade

General dimensions

Size	A	B	C
6"	300	725	110
8"	325	850	140
10"	325	850	180
12"	325	850	220

Dimensions in millimetres

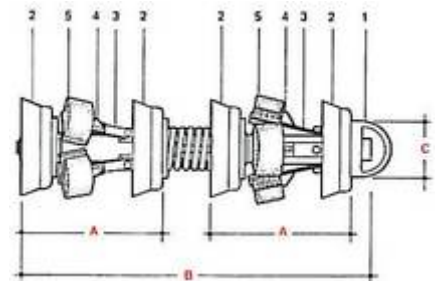

Société Internationale de Produits et Services Industriels
 102 rue J.-B. Charcot
 92400 Courbevoie - France
 ☎ : (33) 01 47 68 75 00
 ✉ : ipsi@ipsifrance.com
 ☎ : (33) 01 47 89 99 39
 🌐 : www.ipsifrance.com

PROTEUS RANGE



SMALL SEPARATION PIG. RIGID 'R' OR FLEXIBLE 'F' BODY SIZE RANGE 2" thro 14" N.S.

SPECIFICATION

- Designed essentially for pigging multi-product, multi-bend pipeline systems.
- Efficient polyurethane cup of flexible design ensures continuity of seal even in 1½D radius bend configurations.
- Traverses 1½D bends, full diameter barred tees, full opening ball, and through conduit valves.
- Will pass localised restrictions (indentations) of up to 20%.
- No exposed metal parts to damage pipeline or fittings.
- Will not damage internally painted or coated pipelines.

PRODUCT GUIDE

- Basic design intended for use as a batching or separation pig.
- Flexibility of cups makes pig ideal for traversing multi-bend pipeline systems in refineries, chemical plants and storage terminals.
- Polyurethane bumper nose prevents damage to pipeline, valves and pig trap door.
- Light in weight very durable pig with easily replaced cups.
- Available with rigid or flexible body.

Nominal Size	A	B	C
2"	135	90	26
3"	170	115	41
4"	225	150	64
6"	310	200	64
8"	370	250	110
10"	470	300	134
12"	540	360	180
14"	620	425	180

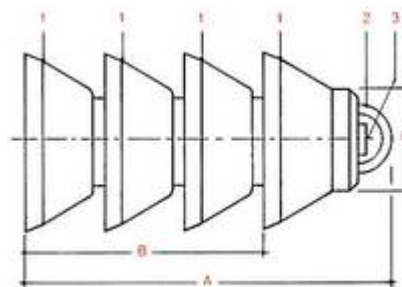

Spare Parts	
Part	Description
1	Driving cup
2	Nose
3	Body

Dimensions in millimetres. Replacement parts are normally available ex-stock.



Société Internationale de Produits et services Industriels

102 rue J.-B. Charcot

92400 Courbevoie - France

☎ : (33) 01 47 68 75 00

✉ : ipsi@ipsifrance.com

☎ : (33) 01 47 89 99 39

🌐 : www.ipsifrance.com

PROTEUS RANGE

SPECIFICATION

- Designed essentially for pigging multi-product, multi-bend pipeline systems.
- Efficient polyurethane cup of flexible design ensures continuity of seal even in 1½D radius bend configurations.
- Traverses 1½D bends, full diameter barred tees, full opening ball, and through conduit valves.
- Traverses gate valves.
- Wire brush cleaning alternative (bolt on kit).
- polyurethane plough blade scraping alternative (bolt on kit).
- Polyurethane protector nose.
- No exposed metallic parts to contact or damage pipe surface.
- Reduced weight.
- Brushes or blades give 360° pipe coverage.
- Long run performance.
- Metallic sections have two coats of chemical resistant and anti-corrosion paint.



16" thro 48" PROTEUS PIG FITTED WITH STAINLESS STEEL TRIM BRUSHES, CONVERSION KIT A

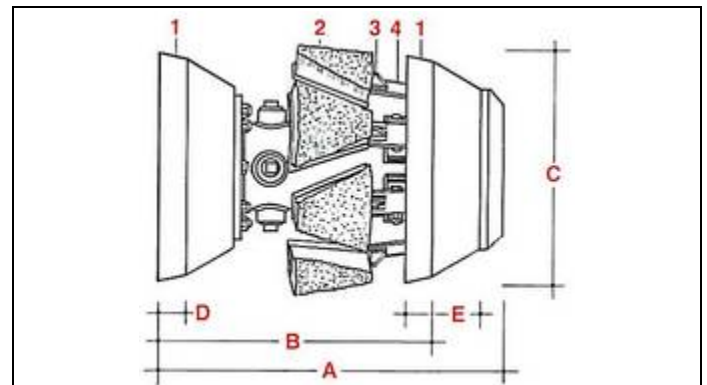

Spare Parts		Conversion kits	
Part	Description	Type	Description
1	Driving cup	A	Cleaning pig with brush units
2	Brush/ plough blade		
3	Guide	B	Cleaning pig with plough blades
4	Spring		

The kits include all the necessary parts to convert from the basic pig

General dimensions

Size	A	B	C	D	E
16"	595	540	405	44	100
18"	685	623	457	44	106
20"	695	605	508	50	140
22"	825	735	560	50	140
24"	850	755	610	60	155
26"	970	880	660	65	155
28"	1005	875	710	70	190
30"	1120	1010	762	80	190
32"	1150	1014	812	80	216
34"	1310	1184	864	90	216
36"	1350	1195	915	100	255
40"	1500	1350	1015	105	255
42"	1535	1350	1067	115	300
48"	1780	1540	1220	120	360

Dimensions in millimetres

PRODUCT GUIDE

- PROTEUS may be run as an effective separation or de-watering tool.
- Conversion kit allows this pig to be simply converted into a three or four cup pig.
- Adequate by-pass facilities are built into pig to allow velocity control and increase cleaning efficiency.
- Heavy duty conical polyurethane cups ensure effective sealing, long run performance and the flexibility to negotiate localised bore restrictions (indentations) of up to 20%.
- PROTEUS IS RIGHT FOR BOTH OPERATOR AND CONTRACTOR.



Société Internationale de Produits et services Industriels

102 rue J.-B. Charcot

92400 Courbevoie - France

☎ : (33°) 01 47 68 75 00

✉ : ipsi@ipsifrance.com

☎ : (33) 01 47 89 99 39

🌐 : www.ipsifrance.com

BI-DIRECTIONAL

IP.BD BI-DIRECTIONAL PIG 2" thro 48"

SPECIFICATION

- Four polyurethane driving discs.
- Polyurethane protector nose.
- Towing eye at each end to facilitate removal.
- Polyurethane mouldings are manufactured in-house to strict quality standards and have exceptionally good physical and chemical-resistant properties.
- High wear and abrasion resistance.
- Traverses full bore ball and conduit valves.
- Traverses barred tees.
- Sizes 2" thro 6" will traverse bends to 3D radius.
- Sizes 8" and above will traverse bends down to 1½D radius.
- Carbon steel body components have two coats of chemical-resistant anti-corrosive paint.

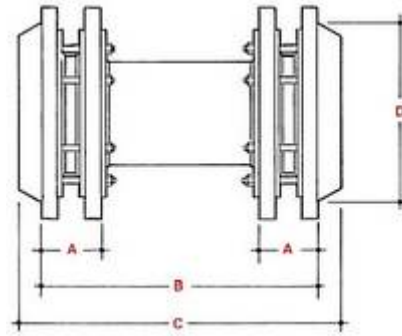

General dimensions

Size	A	B	C	D
2"		75	125	35
3"		100	150	50
4"		150	200	70
6"		200	260	110
8"		250	310	140
10"		300	370	180
12"		375	445	220
14"	100	450	520	250
16"	100	500	570	320
18"	100	550	620	360
20"	125	625	695	400
24"	125	725	825	500
26"	125	775	875	540
28"	125	825	925	590
30"	150	900	1000	630
32"	150	950	1050	670
34"	150	1000	1100	720
36"	175	1075	1175	760
40"	175	1150	1270	860
42"	200	1200	1320	900
48"	200	1400	1520	1060

Dimensions in millimetres

PRODUCT GUIDE

- Bi-directional pigging during hydrostatic testing of pipelines; for both water filling and evacuation duties.
- An alternative to spheres thus eliminating the necessity for sphere tees to be fitted at branches.
- A popular pig with contractors.
- Four sealing faces ensure a good seal is maintained for long periods.
- Useful tool for debris clearance.
- Larger sizes on application.



Société Internationale de Produits et services Industriels

102 rue J.-B. Charcot

92400 Courbevoie - France

☎ : (33°) 01 47 68 75 00

✉ : ipsi@ipsifrance.com

☎ : (33) 01 47 89 99 39

🌐 : www.ipsifrance.com

HI-SEAL BI-DIRECTIONAL



IP. HS HI-SEAL BI-DIRECTIONAL PIG 2" thro 48"

SPECIFICATION

- Polyurethane sealing discs.
- Polyurethane guiding discs.
- Polyurethane protector noses.
- Towing eye at each end to facilitate removal.
- Construction of pig is such that discs will not tear away from body.
- Sizes 4" & 6" will traverse bends down to 3D radius.
- Sizes 8" and larger will traverse bends down to 1½D radius.
- Carbon steel body components have two coats of chemical-resistants anti-corrosive paint.

PRODUCT GUIDE

- Bi-directional pigging for both water filling and evacuation duties.
- Can be fitted with gauging plate.
- Ideal contractor's pig.
- Accurately sized sealing discs ensure an efficient seal is maintained for longer distances.
- Available with various configurations of guiding and sealing discs.
- Will accept magnet packs.
- Interchangeable circular brushes.
- Transmitter housing available.
- Other sizes available.

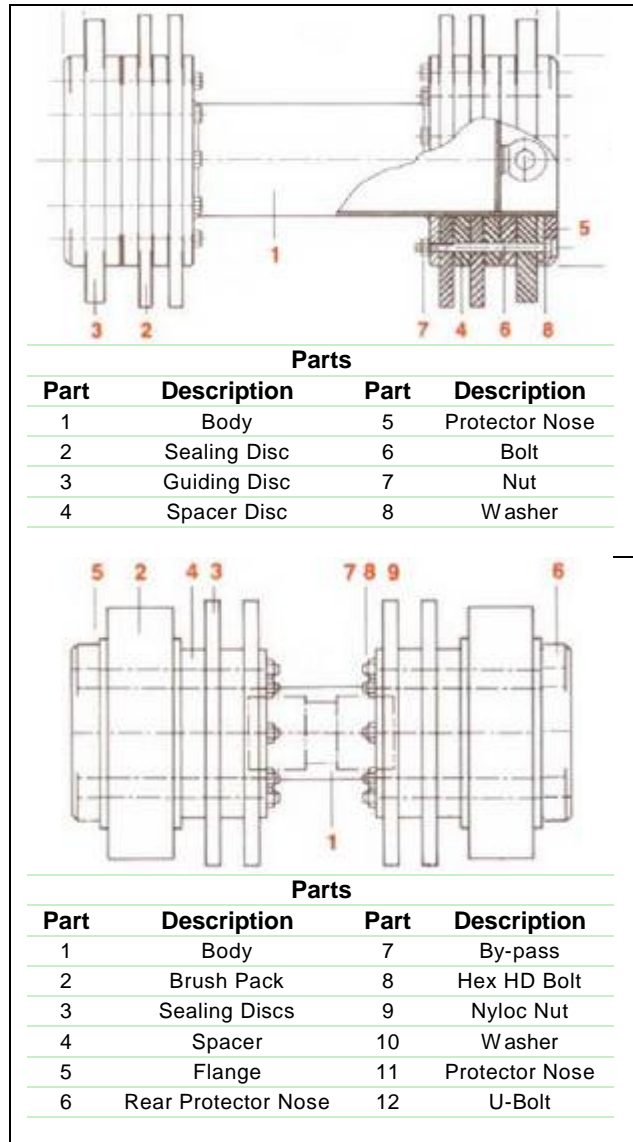

Société Internationale de Produits et services Industriels

102 rue J.-B. Charcot

92400 Courbevoie - France

☎ : (33°) 01 47 68 75 00

✉ : ipsi@ipsifrance.com

☎ : (33) 01 47 89 99 39

🌐 : www.ipsifrance.com

FLEXICAST RANGE



SPECIFICATION

- Manufactured from high performance , elastomer.
- Six hi-seal discs accurately sized for optimum performance.
- Excellent physical and chemical resistant properties.
- Will traverse bends down to 1½D radius.
- Will negotiate full bore ball and through conduit valves.
- Traverses up to 90° full diameter barred side branches.
- May be fitted with nylon rope towing eye.

PRODUCT GUIDE

- Suitable for uni or bi-directional operations.
- Flexi-cast is ideal for separation, batching and product evacuation.
- Excellent tool for use on hydrostatic testing operations.
- Design of pig allows for accurate sizing of disc thus ensuring optimum sealing performance.
- One piece moulding - no replacement parts required.
- Easy to clean and light to handle.

Nominal Size	A	B	C	D
2"	55	30	75	124
3"	81	40	114	167
4"	107	63	138	207
6"	166	80	222	301
8"	212	117	284	365
10"	264	130	356	444
12"	316	148	454	553
14"	349	158	474	598

Dimensions in millimetres

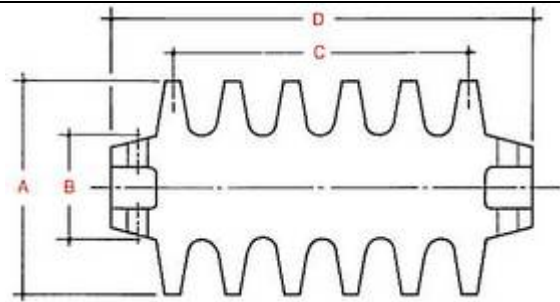

Société Internationale de Produits et services Industriels

102 rue J.-B. Charcot
92400 Courbevoie - France

☎ : (33°) 01 47 68 75 00
✉ : ipsi@ipsifrance.com

📞 : (33) 01 47 89 99 39
🌐 : www.ipsifrance.com

DRIVING CUPS



2" thro 56" DRIVING CUP

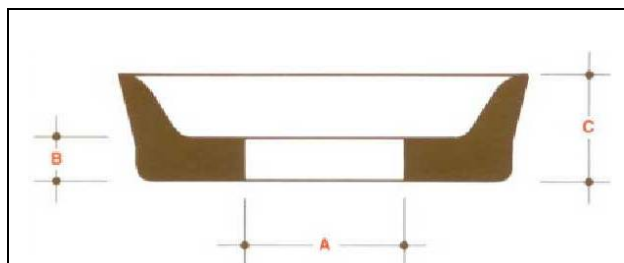

SPECIFICATION

- Cups are manufactured from a polyurethane elastomer having exceptionally good seal and low compression set characteristics.
- Polyurethane mouldings are manufactured in-house to strict quality standards and have exceptionally good physical and chemical-resistant properties.
- High wear and abrasion resistance.
- Suitable for use in crude oil, natural and industrial gases, vegetable oils, general chemicals and effluents.
- Mounting holes to suit client's requirements.
- Special cups available to suit non-standard applications.

PRODUCT GUIDE

- Driving cups are designed primarily as advanced components for our own range of pigs.
- Compatible with and available for a wide range of other pigs currently in service.

General dimensions

Size	A	B	C
2"	16	10	28
3"	22	12	30
4"	22	12	35
6"	22	20	50
8"	35	20	60
10"	35	25	65
12"	35	25	65
14"	35	28	70
16"	225	28	75
18"	225	28	75
20"	280	32	82
22"	310	32	82
24"	360	32	82
26"	360	32	90
28"	465	32	92
30"	465	32	95
32"	465	32	98
34"	465	35	98
36"	570	35	98
38"	615	35	98
40"	615	35	98
42"	615	38	98
44"	720	38	100
46"	770	38	100
48"	870	38	100
50"	870	38	100
52"	920	40	105
56"	970	40	105

Dimensions in millimetres



Société Internationale de Produits et services Industriels

102 rue J.-B. Charcot

92400 Courbevoie - France

☎ : (33°) 01 47 68 75 00

✉ : ipsi@ipsifrance.com

☎ : (33) 01 47 89 99 39

🌐 : www.ipsifrance.com

SCRAPER DISCS

2" thro 48" SCRAPER DISC



SPECIFICATION

- Bi-directional.
- Discs are manufactured from a polyurethane elastomer having exceptionally good seal and low compression set characteristics ; high wear and abrasion resistance.
- Polyurethane mouldings are manufactured in-house to strict quality standards and have exceptionally good physical and chemical-resistant properties.
- Suitable for use in crude oil natural and industrial gases, vegetable oils, general chemicals and effluents.
- Mounting holes to suit client's requirements.
- Special materials and various hardnesses available.

PRODUCT GUIDE

- Scraper discs are designed primarily as advanced components for our own range of pigs.
- Compatible with and available for a wide range of other pigs currently in service.
- Rugged standard specification discs make them ideal for fitting to pigs used during hydrostatic testing operations and services where it is required to reverse the run direction of the pig without removing it from the pipeline.
- Careful sizing ensures efficient sealing and long run performance.
- In many cases scraper discs may be used rather than conventional cups to improve scraping, separation and cleaning operations.

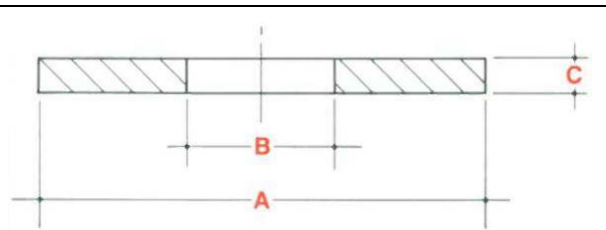

General dimensions

Size	A	B	C
2"	55	16	10
3"	80	22	12
4"	105	22	12
6"	155	22	20
8"	210	35	20
10"	260	35	25
12"	310	35	25
14"	355	35	28
16"	405	225	28
18"	460	225	28
20"	510	280	32
22"	565	310	32
24"	615	360	32
26"	665	360	32
28"	720	465	32
30"	775	465	32
32"	825	465	32
34"	880	465	35
36"	930	570	35
38"	985	615	35
40"	1040	615	35
42"	1090	615	38
48"	1245	870	38

Dimensions in millimetres



Société Internationale de Produits et services Industriels

102 rue J.-B. Charcot

92400 Courbevoie - France

☎ : (33°) 01 47 68 75 00

✉ : ipsi@ipsifrance.com

☎ : (33) 01 47 89 99 39

🌐 : www.ipsifrance.com

CLEANING BRUSH UNITS



PROTEUS BRUSH UNIT

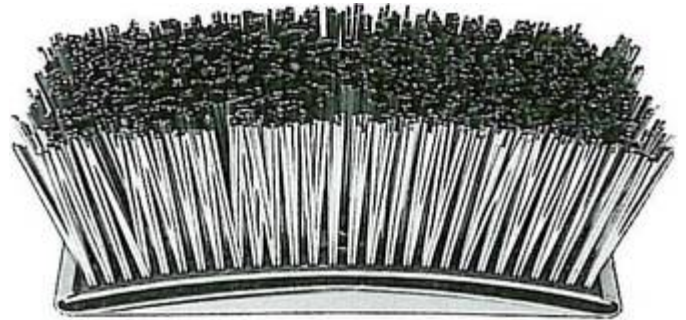

IP. UG BRUSH UNIT

SPECIFICATION

- Each bristle is of stainless steel rectangular section to give more effective cleaning.
- Bristle support plates and backing plates formed to match the relevant pipeline bore diameters.
- Bristles retained by stainless steel locking wire.
- Brush units are supplied complete with backing plates and drilled for mounting onto spring arms.
- Carbon steel bristles may be supplied.
- Technical staff are available to discuss any special requirements.



IP. RCN CIRCULAR BRUSH 3" thro 8"

PRODUCT GUIDE

- The traditional method of pipeline scraping - steel brush units mounted on spring arms for use on cleaning pigs.
- Designed primarily to cover the whole range of cleaning pig requirements of designs, they are also compatible with and available for a wide range of other cleaning pigs currently in service.



IP. RCN BRUSH UNIT 10" thro 18"



Société Internationale de Produits et services Industriels

102 rue J.-B. Charcot
92400 Courbevoie - France

☎ : (33°) 01 47 68 75 00
✉ : ipsi@ipsifrance.com

☎ : (33) 01 47 89 99 39
🌐 : www.ipsifrance.com

CLEANING PLOUGH / SCRAPER BLADES

SPECIFICATION

- Two Forms :
 - a) small and large plough blades,
 - b) small and large diagonally mounted scraper blades.
- Polyurethane mouldings are manufactured in -house to strict quality standards and have exceptionally good physical and chemical-resistant properties.
- High wear and abrasion resistance.
- Suitable for use in crude oil, natural and industrial gases, vegetable oils, chemicals and effluents.
- Ploughs and scrapers supplied drilled for mounting onto spring arms.
- Specials on request.

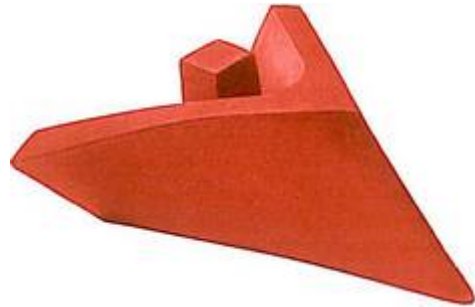

TYPE P1 FOR IP.K3 6" thro 8"
TYPE P2 FOR IP.K3 10" thro 12"



TYPE S1 FOR IP. UG AND PROTEUS 12" thro 18"

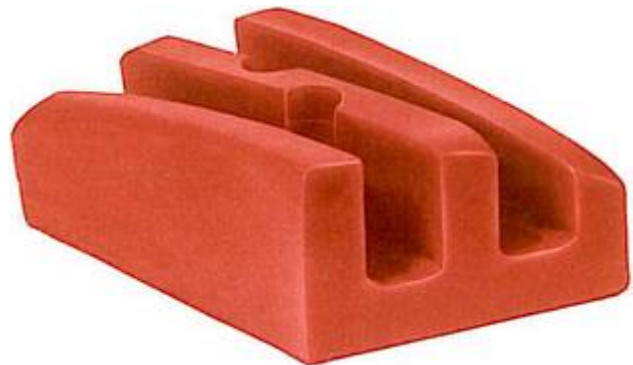

TYPE S2 FOR IP. UG AND PROTEUS 20" thro 48"

PRODUCT GUIDE

- Polyurethane scraper blades are alternative to metallic brush units.
- For use in pipeline scraping duties where traditional metallic brushes would be too severe e.g. internally coated lines, waxy or high viscous deposits.
- Designed primarily as advanced components for our own range of pigs they are also compatible with and available for a wide range of other cleaning pigs currently in service.



Société Internationale de Produits et services Industriels

102 rue J.-B. Charcot

92400 Courbevoie - France

☎ : (33°) 01 47 68 75 00

✉ : ipsi@ipsifrance.com

☎ : (33) 01 47 89 99 39

🌐 : www.ipsifrance.com

MONITOR RANGE

SPECIFICATION

- Suitable for any pipe size from 3" nominal.
- Standard pressure range up to ANSI 900.
- Higher pressure range available to specification.
- NACE conformity.
- Principle feature of operation by rare earth magnets.
- Lo-torque trigger.
- Internal moving parts stainless steel.
- All seals standard metric.
- 'O' rings viton unless otherwise specified.



VISUAL MECHANICAL DIRECT MOUNTED MODEL 'MW'

PATENT PENDING

- ### PRODUCT GUIDE
- The Monitor range is specifically designed, in concept and detail, to overcome the limitations of earlier signalling methods.
 - The sensor probe (trigger) is omni-directional : it can neither damage pigs or spheres nor be damaged by their passage.
 - Trigger has 100% free movement therefore positioning of welding boss is unrestricted.
 - Indicator flag is rotatable in 90° increments to obtain the most visible vantage.
 - Available for use with foam and polly pigs.
 - Positive action indicator flag is instantly re-set.
 - No moving seals, thus minimising the possibility of product leakage from the pipeline.
 - Simple concept -maintenance free.
 - Easily adapted for existing welding connections to replace worn or defective units.

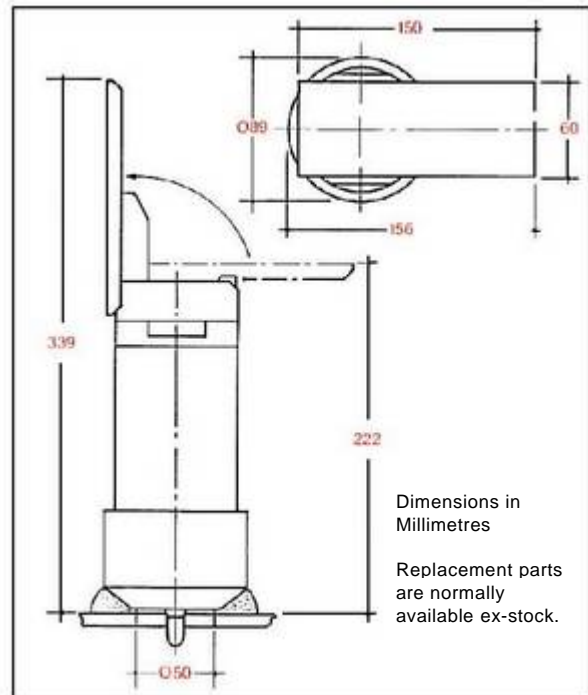

Société Internationale de Produits et services Industriels

102 rue J.-B. Charcot

92400 Courbevoie - France

☎ : (33°) 01 47 68 75 00

✉ : ipsi@ipsifrance.com

☎ : (33) 01 47 89 99 39

🌐 : www.ipsifrance.com

The Monitor range of pig passage indicators is designed and built to overcome the limitations found in earlier types of signalling equipment. Materials, design and manufacturing standards have produced a pig passage indicator that is maintenance free, easy to install and suitable for every pipeline situation.

Visual indication
 Remote electrical signal
 Buried pipelines
 Removal under pressure

All models have the following specification and features in common.

SPECIFICATION

- Suitable for any pipe size from 2".
- Pressure range up to ANSI 2500.
- Conformity to NACE MR-01-75.
- Lo-torque trigger.
- Internal moving parts in stainless steel.
- Metric sized 'O' ring seals.

PRODUCT GUIDE

- The trigger is omni-directional and can neither damage nor be damaged by pigs or spheres.
- Welding boss can be positioned in any orientation.
- Works with foam and polly pigs.
- No moving seals, therefore minimal possibility of product leakage.
- Maintenance free.
- Adapts easily to existing connections to replace worn or defective units.



MECHANICAL DIRECT MOUNTED MODEL 'MW'

- Positive action instant re-set indicator flag.
- Indicator flag rotatable in 90° increments for optimum visual sighting.



VALVED MECHANICAL DIRECT MOUNTED MODEL 'MVW'

- Removable and replaceable under pipeline pressure.
- Positive action instant re-set indicator flag.
- Indicator flag rotatable in 90° increments for optimum visual sighting.



VALVED COMBINED MECHANICAL-ELECTRICAL DIRECT MOUNTED MODEL 'CVW'

- Removable and replaceable under pipeline pressure.
- Local visual and remote panel indication in a single pig passage indicator.



COMBINED MECHANICAL-ELECTRICAL DIRECT MOUNTED MODEL 'CW'

- Local visual and remote panel indication in a single pig passage indicator.



Société Internationale de Produits et services Industriels

102 rue J.-B. Charcot

92400 Courbevoie - France

☎ : (33°) 01 47 68 75 00

✉ : ipsi@ipsifrance.com

☎ : (33) 01 47 89 99 39

🌐 : www.ipsifrance.com

MONITOR SELECTION GUIDE AND DATA SHEET

PRODUCT GUIDE

- The monitor range of pig passage indicators is specifically designed, in concept and detail, to overcome the limitations of earlier signalling methods.
- The sensor probe (trigger) is omni-directional : it can neither damage pigs or spheres nor be damaged by their passage.
- Trigger has 100% free movement - therefore positioning of welding boss is unrestricted and may be mounted either on the top or the side of a pipeline.
- Indicator flag is rotatable in 90 degree increments to maximise visibility.
- Available for use with foam and polly pigs (extended triggers available to order).
- Positive action indicator flag may be instantly re-set.

The Monitor range of pig passage indicators provides several options :

- flanged mounting to the pipeline,
- extension bodies for use with buried pipelines to a maximum length of 3000 mm,
- pressure rating to ANSI 2500,
- retro-fit to existing mounting.

APPLICATION

This is an omni trigger operated unit. The principle feature consists of a magnetic link between two packs of rare earth magnets.

The trigger is omni-directional and may also be actuated upwards as a plunger. When the trigger is actuated (very low torque is required) a follower mechanically moves a magnet pack axially in the indicator body. The magnet pack is strongly linked to a second magnet pack and shaft which move axially within an un-pressurised housing.

The movement of the shaft operates a visual, manual re-set flag and/or activates a limit-switch (auto-reset), giving a positive indication that a pig or sphere has passed the indicator.

The flag may be set such that it can be seen from any given direction.

SPECIFICATION

- Suitable for any pipe size from 2 inch nominal?
- Pressure range up to ANSI 2500,
- Conformity to NACE MR-01-75,
- Principle feature of operation by rare earth magnets,
- Low-torque trigger,
- Internal moving parts in stainless steel,
- All seals standard metric sizes.
- Flanged mounting to the pipeline.
- Extension bodies for use with buried pipelines to a maximum length of 3000mm.
- Pressure ratings to ANSI Class 2500
- Retro-fit to existing mounting

The full ordering code is :

Model	D Direct mounted V Removable under pressure
Indication type	M Mechanical visual flag E Electrical switch C Visual flag and electrical switch
Pipeline mounting	W Welding boss with screwed fitting F Welding boss with flanged mounting C Gray loc type hub connection
Special options	X Extension body (state length of extension required) H High pressure (state design and working pressure) S Special seals (state material or product in pipeline) Y Retro-fit to existing boss or flange (state type or make of mounting)



Société Internationale de Produits et services Industriels

102 rue J.-B. Charcot

92400 Courbevoie - France

☎ : (33) 01 47 68 75 00

✉ : ipsi@ipsifrance.com

☎ : (33) 01 47 89 99 39

🌐 : www.ipsifrance.com

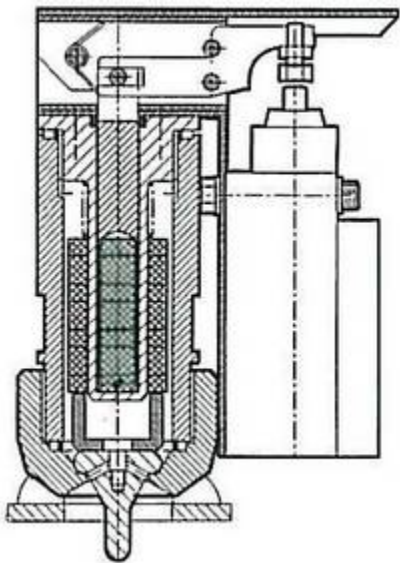

COMBINED MECHANICAL-ELECTRICAL
DIRECT MOUNTED MODEL 'CW'

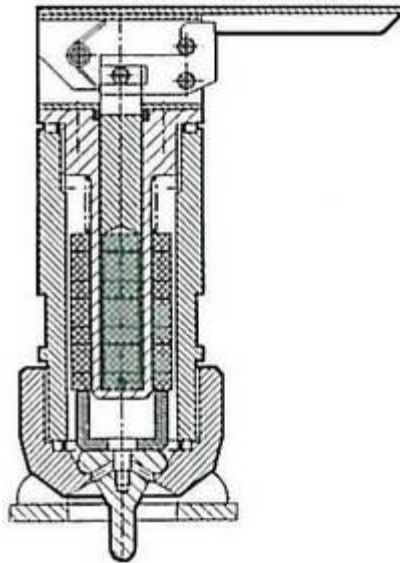

MECHANICAL DIRECT
MOUNTED MODEL 'MW'

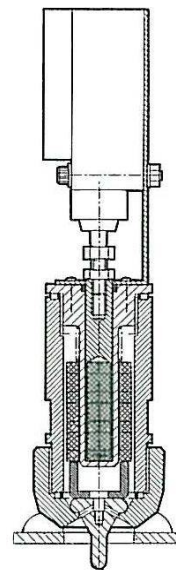

ELECTRICAL DIRECT
MOUNTED MODEL 'EW'

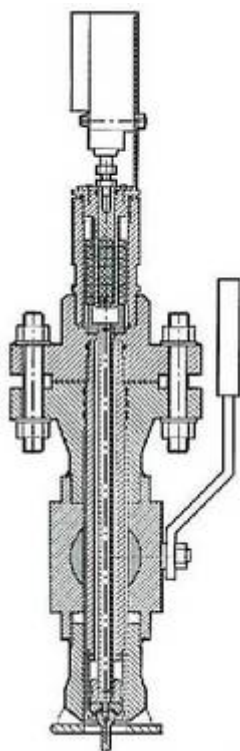

VALVED ELECTRICAL DIRECT
MOUNTED MODEL 'EVW'

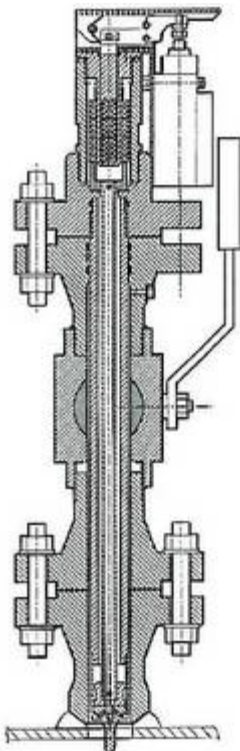

VALVED COMBINED MECHANICAL- ELECTRICAL
FLANGE MOUNTED MODEL 'CVF'

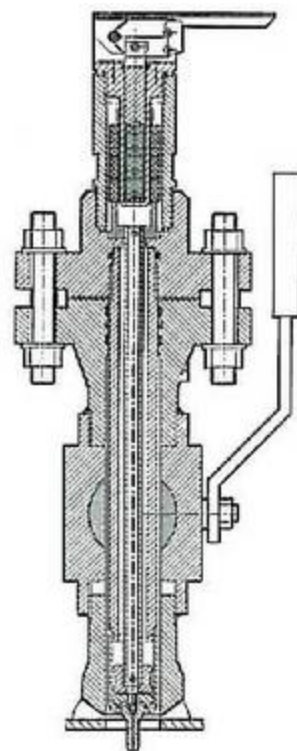

VALVED MECHANICAL DIRECT
MOUNTED MODEL 'MVW'



Société Internationale de Produits et services Industriels

102 rue J.-B. Charcot

92400 Courbevoie - France

☎ : (33) 01 47 68 75 00

✉ : ipsi@ipsifrance.com

☎ : (33) 01 47 89 99 39

🌐 : www.ipsifrance.com

PIG LOCATION SYSTEM

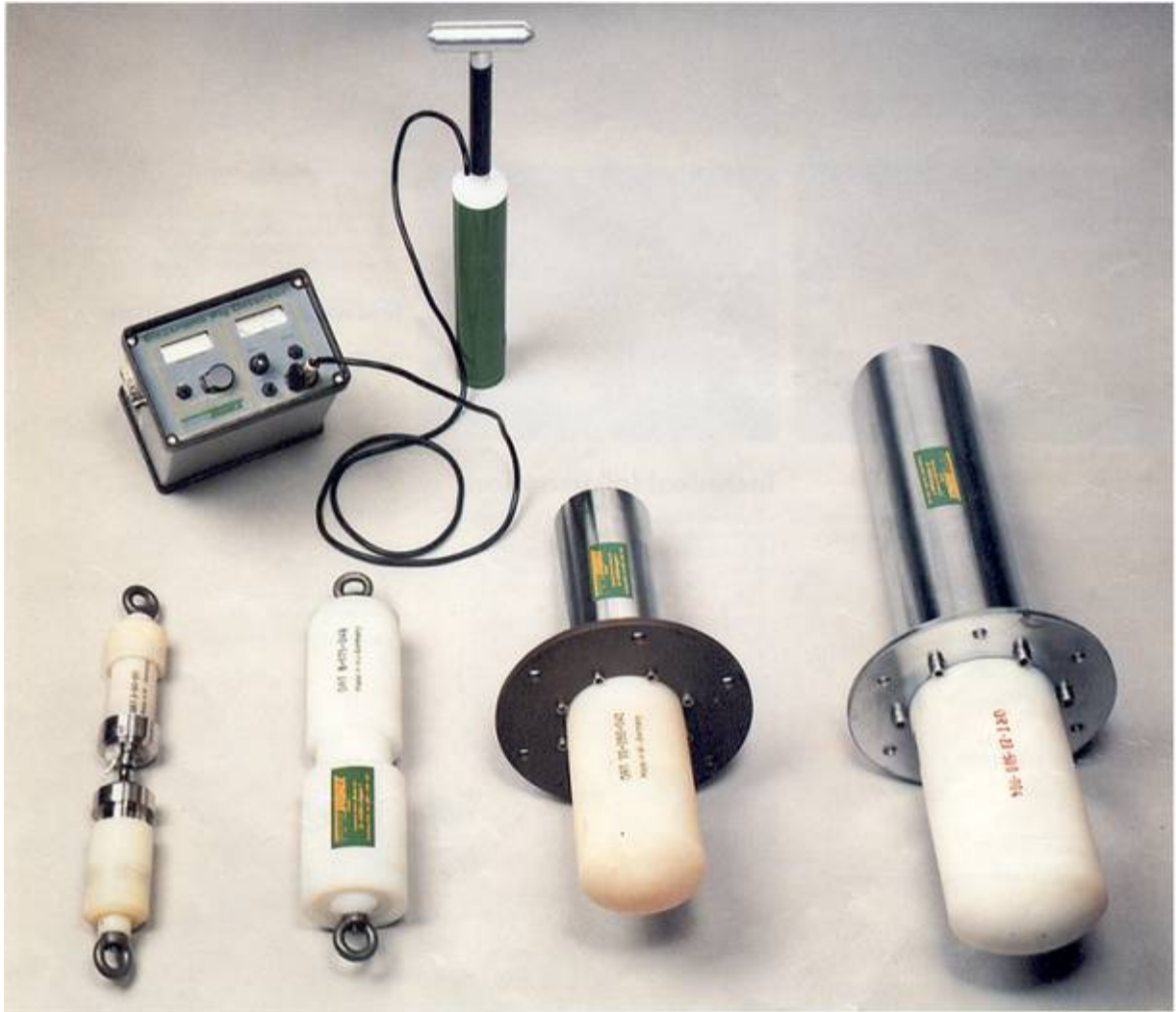

Société Internationale de Produits et services Industriels

102 rue J.-B. Charcot

92400 Courbevoie - France

☎ : (33°) 01 47 68 75 00

✉ : ipsi@ipsifrance.com

☎ : (33) 01 47 89 99 39

🌐 : www.ipsifrance.com

General Information

Pig Location System, with C-Mos microprocessor technology, able to track and locate all kinds of pigs used in the pipeline industry.

The system has been designed to cover a wide range of tracking and locating applications:

- Pigging of new pipelines during hydrostatic testing
- Pigging of on-stream pipelines
- Batching operations
- Running of intelligent pigs

The Pig Location System consists of a transmitter, a receiver and an antenna; it can be operated over long periods under difficult conditions.



Transmitter

The pig, to be located, is equipped with a transmitter, which sends out a low frequency signal through the pipe wall and cover



Built-in and towable transmitters

Due to the low frequency signals of the transmitter, it is possible to track a stuck pig with an accuracy of 0.5 m.

Sizes

- Battery life 80 hours
length 210 mm
diameter: 60 mm
- Battery life 175 hours
length 350 mm
diameter: 80 mm
- Battery life up to 250 hours
length 450 mm
diameter: 120 mm
- Battery life 500 hours
length 650 mm
diameter: 120 mm
- Special battery lifetime available upon request

Special designed transmitter for small sizes able to negotiate narrow bends



Technical Information

- Transmitted signals are analysed by a C-Mos microprocessor
- Built-in audio-visual perception signal
- Illuminated LCD-timer for pig passage
- Potential-free output contact for remote perception
- Water-proof casing
- Power supply from long life battery

Receiver Unit including antenna

The Receiver Unit consists of a battery powered display unit and an antenna. The components, made of aluminium and synthetic material, are extremely robust and absolutely weather-proof.

Delivery Programme

1. Transmitters

- 3" up to 6" ORT 3- 80
- 8" up to 18" ORT 8-175
- 20" upwards ORT 20-250
- 20" upwards ORT 20-500
- 20" upwards ORT 20-x

2. Receiver Unit

Consists of:

- Receiver/Display
- Antenna
- Earphones (optional)
- Hand carrying box

Applicable for all transmitters



Société Internationale de Produits et services Industriels

102 rue J.-B. Charcot

92400 Courbevoie - France

☎ : (33) 01 47 68 75 00

✉ : ipsi@ipsifrance.com

☎ : (33) 01 47 89 99 39

🌐 : www.ipsifrance.com

GAS BAG

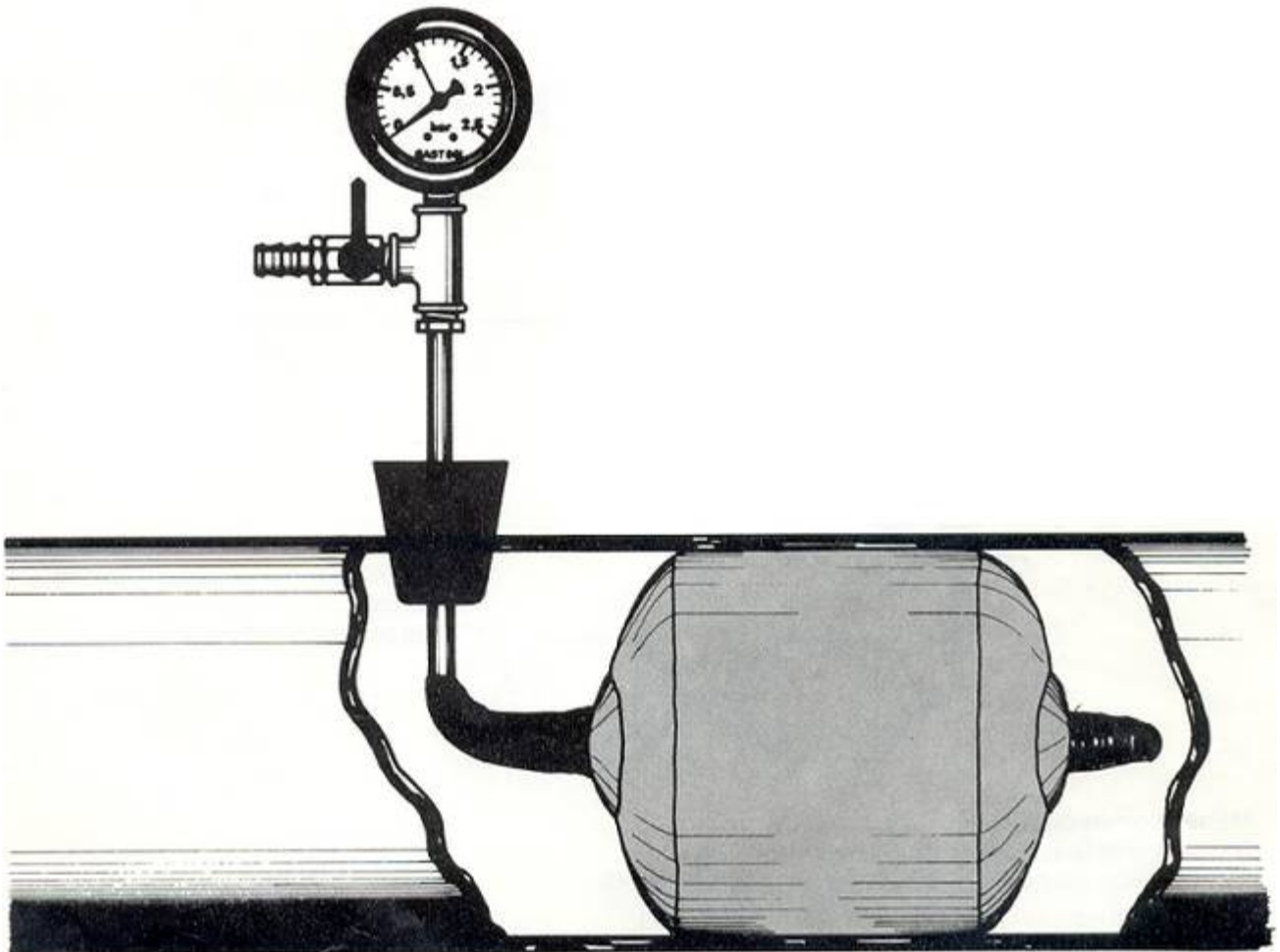

For high and medium pressure gas lines



Société Internationale de Produits et services Industriels

102 rue J.-B. Charcot

92400 Courbevoie - France

☎ : (33) 01 47 68 75 00

✉ : ipsi@ipsifrance.com

☎ : (33) 01 47 89 99 39

🌐 : www.ipsifrance.com

TYPE A
SINGLE BAG FOR MEDIUM PRESSURE LINES.

Models available : 1/2 ; S/L/O ; G.
Basic equipment : valve with nipple and standard rubber plug (except G).
For nominal diameters from 50 mm to 1000 mm (2" to 40").

TYPE B
SINGLE BAG WITH LINE INTERNAL PRESSURE MEASURING EQUIPMENT, FOR MEDIUM PRESSURE LINES

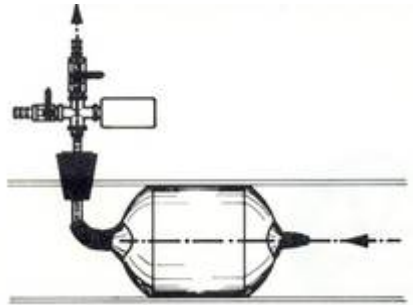

Models available : as type A..
For nominal diameters from 50 mm to 600 mm (2" to 24").

TYPE C
DOUBLE BAG FOR MEDIUM PRESSURE LINES

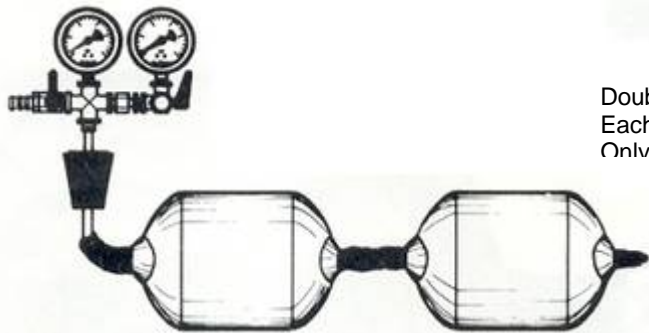

Double Bag ° Double safety.
Each bag with own air input.
Only one boring is needed on the line

Models available : as type A.
Basic equipment : two valves with nipples, two manometers and standard rubber plugs (except G).
For nominal diameters from 50 mm to 400 mm (2" - 16").

TYPE D
SINGLE BAG FOR HIGH PRESSURES

Models available : S/L/O ; G/P.
Basic equipment : bag with Terylene sleeve, valve and nipple.
For nominal diameters from 50 mm to 600 mm (2" - 24").



Société Internationale de Produits et services Industriels

102 rue J.-B. Charcot

92400 Courbevoie - France



☎ : (33°) 01 47 68 75 00

✉ : ipsi@ipsifrance.com

☎ : (33) 01 47 89 99 39

🌐 : www.ipsifrance.com

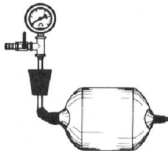
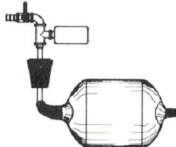
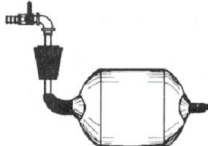
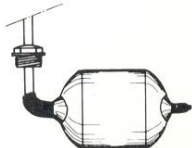
Possible executions are described here under.
 Consult the following synopsis to order the type and model required.
 The execution index code must appear in the order designation*.

Index	Execution	
1	Bag with anti-static tear-resistant	
2	Bag with Terylene sleeve (for bag internal high pressures).	
S	Manometer (with manometer protection) for control of bag internal pressure. Vertical position.	
L	Manometer (with manometer protection) for control of bag internal pressure. Horizontal position.	
O	Without manometer	
G	With threaded plug and reinforced shaft.	
P	With rubber pressure plug and reinforced shaft.	 <p>A turning ear drives the plug under pressure into the borehole.</p>

* *Examples of designations :

1) Designation of double bag with Terylene sleeve, vertical manometer end threaded plug for 10" pipe :

Gas Stopping Bag type C 10" 2-S-G

2) Designation of single bag with plastic sleeve, horizontal manometer and standard rubber plug for 20" line :

Gas Stopping Bag type A 20" 1-L



Société Internationale de Produits et services Industriels

102 rue J.-B. Charcot

92400 Courbevoie - France

☎ : (33°) 01 47 68 75 00

✉ : ipsi@ipsifrance.com

☎ : (33) 01 47 89 99 39

🌐 : www.ipsifrance.com

TABLES OF DIMENSIONS AND CORRESPONDING INTERNAL PRESSURES FOR DSI - GAS STOPPING BAGS

DN in mm	Medium pressure in bars	High pressure in bars
50	2,0	2,5
63		
80		
90		
100		
110		
125	1,5	2,0
150		
160		
175		
200	1,0	1,5
225		

DN in mm	Medium pressure in bars	High pressure in bars
250	0,8	1,0
300	0,7	
350	0,6	0,8
400	0,5	
450	0,4	0,6
500		
600	0,3	0,4
700	0,2	0,3
750		
800	0,2	0,25
900		
1000	0,2	0,23

SPARE PARTS

Separately available: anti-static sleeve, Terylene sleeve, sleeveless rubber bag, manometer with Plexiglas dial cover, manometer protection caps, valves with nipple, hose clips.

SPECIAL ACCESSORIES

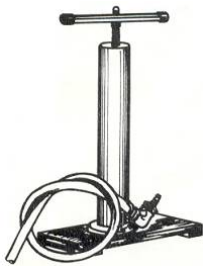

Inflating pump with 2 connection pieces included : 1 meter hose.

LINE TEST PLUGS

Dimensions 1/2" / 3/4" / 1" / 1 1/2" / 2".

Type 1
One nipple with stopcock



Type 2
One nipple without stopcock



Type 3
Two nipples with stopcock



Type 4
Two nipples without stopcock



Observation :

This leaflet, based on our experience, must be regarded as technical information. Our guarantee only covers the replacement of faulty material. It is up to the user to check that our products are suitable to each application, and he shall bear the risks of such applications.



Société Internationale de Produits et services Industriels

102 rue J.-B. Charcot

92400 Courbevoie - France

☎ : (33°) 01 47 68 75 00

✉ : ipsi@ipsifrance.com

☎ : (33) 01 47 89 99 39

🌐 : www.ipsifrance.com

EXPANDING PIPE STOPPERS

IPSI, drain plugs are designed and manufactured to a high specification to give quick & successful results. Plugs are available in pressed steel and pressed aluminium in 100 mm (4") & 150 mm (6").

Sizes 200 mm (8"), 300 mm (12"), 375 mm (15"), 400 mm (16") 600 mm (24") are available in new cast aluminium.

All other sizes are cast iron.

Best quality rubber seals are fitted as standard. Caps are brass on 2" outlet plugs and plastic on ½" & 1" outlets (½" & 1" brass caps available on request).

Roller washers are fitted on 2" outlet plugs. 1" roller washers available on request.

DOUBLE SEAL plugs available on request for special applications & in uneven pipes.

Note: Progressively other sizes may be changed to Aluminium castings.

MAXIMUM DIAMETER : 1220 mm (48")

MINIMUM DIAMETER : 37 mm (1½")

THREADED OUTLET SIZES :

1220 mm (48") to 430 mm (17") 2" BSP outlet

400 mm (16") to 175 mm (7") 1" BSP outlet

150 mm (6") to 37 mm (1½") ½" BSP outlet

Please note that sizes 100 mm (4"), and 150 mm (6") can be supplied with 1" BSP outlet if required.

Owing to the variation in wall thickness in certain types of pipes it is essential when ordering to state the actual diameter of the pipe concerned.

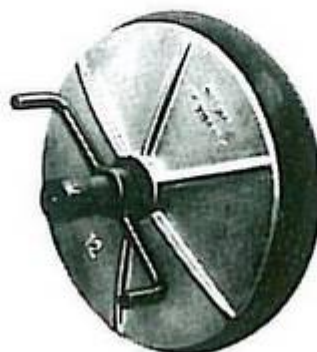
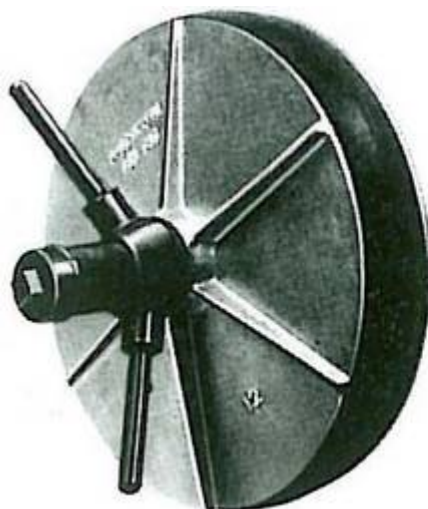
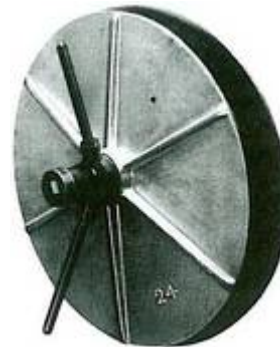

MANUFACTURED IN A COMPREHENSIVE RANGE OF SIZES SUITABLE FOR MOST INTERNAL DIAMETERS OF PIPE.



Société Internationale de Produits et services Industriels

102 rue J.-B. Charcot

92400 Courbevoie - France

☎ : (33) 01 47 68 75 00

✉ : ipsi@ipsifrance.com

☎ : (33) 01 47 89 99 39

🌐 : www.ipsifrance.com

INFLATABLE AIR BAG STOPPERS

Manufactured in heavy duty canvas. Available 3" - 24" from stock
Over 24" to special order.



SELF-CENTRALISING STOPPERS FOR PIPE TESTING FLUSHING AND HOT WORK



Expanding pipe stoppers with extended centre tube and spider arms.

The extended tube allows the plug to operate approximately 300 mm (12") inside the pipe when necessary and the spider arms keep the stopper centralised during positioning and expansion.

Can be supplied with standard brass caps as shown on the middle two illustrations or special hose connectors as shown on the two outside illustrations. Please state requirements when ordering.

Self- centralising stoppers can be supplied in all sizes from 1220 mm (48") to 50 mm (2").

Please note that 175 mm (7") is the smallest size to which spider arms are fitted. Roller washers are fitted on all 1" and 2" BSP outlets. Rubber rings are fitted as standard.

Owing to variation of wall thickness on certain types of pipes it is essential when ordering to state the actual inside diameter of the pipe concerned.



Société Internationale de Produits et services Industriels

102 rue J.-B. Charcot

92400 Courbevoie - France

☎ : (33°) 01 47 68 75 00

✉ : ipsi@ipsifrance.com

☎ : (33) 01 47 89 99 39

🌐 : www.ipsifrance.com

NYLON EXPANDING DRAIN PLUGS

This, long established, range of Nylon Expanding Drain & Pipe Test Plugs is manufactured from injection moulded components and rubber expansion rings. The unique assembly of the central waterway into the base plate via a snap taper fit and "O" ring seal provides a positive water and air tight joint. The provision of a friction reducing acetal copolymer thrust washer, inserted between the wing nut and top plate facilities easy expansion. All plugs have a central waterway of ½" - 12.7 mm bore.

These Plugs conform to BS8005. for low pressure testing and sealing of pipes.

Note : They are slightly less efficient at the extreme higher limits of expansion than in the middle and lower ranges.



Sizes available are for pipe bore sizes :

½" – 38 mm
2" – 50 mm
2½" – 65 mm
3" – 75 mm
4" – 100 mm
5" – 125 mm
6" – 150 mm

SMALL BORE EXPANDING PLUGS

The range of small bore plugs is constructed from injection moulded Nylon Components and rubber rings. As with our standard plugs, they enjoy the same advantages of being light, non-rusting, easy to expand and clean.

These plugs will seal airtight and in tests with plastic pipes are capable of sealing against pressures from 60 psi - 4 bar, to over 100 psi - 7 bar.

Effective sealing is simple, insert the plug into pipe opening and tighten Wing Nut clockwise, the rubber ring will expand and provide a positive seal. To remove just reverse the above process.

APPLICATIONS

They are in normal useage for plumbing operations in a wide variety of industries. Further and increasingly more important is their use in the fibre-optic industry, principally in the construction and installation of ducting or conduit which carries or will carry fibre-optic cable. Contractors also use them to make a positive water-tight seal to prevent contamination by water, gas, litter, rodents etc.

Their use is important in the preparation of ducting and conduit especially for on-site thermo-forming of bends, kicks, off-sets etc., and are usually supplied by the original equipment manufacturer.

Sizes available are for pipe bore sizes :

½" - 12.7 mm
¾" - 19.0 mm
1" - 25.4 mm
1¼" - 32.0 mm
1½" - 38.0 mm



Société Internationale de Produits et services Industriels

102 rue J.-B. Charcot
92400 Courbevoie - France

☎ : (33°) 01 47 68 75 00
✉ : ipsi@ipsifrance.com

☎ : (33) 01 47 89 99 39
🌐 : www.ipsifrance.com

ALUMINIUM EXPANDING DRAIN PLUGS



Sizes available are for pipe bore sizes :

with ½" Outlet

3" – 75 mm 4" – 100 mm
3½" – 85 mm 5" – 125 mm
6" – 150 mm

with 1" Outlet

4" – 100 mm	14" – 350 mm
6" – 150 mm	15" – 375 mm
7" – 175 mm	16" – 400 mm
8" – 200 mm	18" – 450 mm
9" – 225 mm	20" – 500 mm
10" – 250 mm	21" – 525 mm
12" – 300 mm	24" – 600 mm

Cast Aluminium Expanding Drain and Pipe Plugs.

To complete the range of Expanding Plugs we offer an extensive range of cast aluminium plugs. These are provided firstly in sizes up to 6" for more arduous duty such as long immersion in water and higher temperature applications and, secondly, in sizes up to 24" dia. where it would be uneconomical to manufacture nylon plugs.

They are manufactured with ½" and 1" outlet bores.

All plugs conform to BS8005. for low pressure testing and sealing of pipes.

Note : They are slightly less effective at extreme higher limits of expansion than in the middle and lower ranges.



Société Internationale de Produits et services Industriels

102 rue J.-B. Charcot

92400 Courbevoie - France

☎ : (33) 01 47 68 75 00

✉ : ipsi@ipsifrance.com

☎ : (33) 01 47 89 99 39

🌐 : www.ipsifrance.com

VACUUM BOX INSPECTION SYSTEM V600 & V400

The weld is flooded with detergent solution and the vacuum box placed over the top.

The open edge of the vacuum box incorporates a soft but hard wearing neoprene seal so a vacuum can be generated within the box.

The operator views the weld area through a clear polycarbonate observation window in the top of the box.

A stream of bubbles will indicate any leaks in the weld.

A vacuum relief valve is incorporated in the system to prevent damage to the vacuum box.

This is set at 20in.Hg (10 psi) ensuring that the most stringent requirements of EEMUA, API and ASME are met.

Weld inspection equipment :



The V400 Vacuum Box



The Vacuum Pump



**V600 Vacuum Gauge
and Release Valve**



V600 Vacuum Box



Société Internationale de Produits et services Industriels

102 rue J.-B. Charcot

92400 Courbevoie - France

☎ : (33°) 01 47 68 75 00

✉ : ipsi@ipsifrance.com

☎ : (33) 01 47 89 99 39

🌐 : www.ipsifrance.com

V600 Vacuum Box	
Dimensions	Length 760mm (30inch) x Width 263mm (10.35inch) Height 145mm (5.7inch)
Weight	11 kg
Weld test length	600mm (24inch)
Weld type	Tank floor lapwelds and butt welds.
Tank Diameter	All tank diameters

V400 Vacuum Box	
Dimensions	Length 550mm (21 inch) - height and width depend on angle
Weight	7kg
Weld test length	400mm (16inch)
Weld type	Shell to annular welds.
Tank Diameter	5 meter diameter and over

Vacuum Pump (used with both boxes)	
Dimensions	Length 403mm (15.88inch) x Width 165mm (6.5inch) x Height 236 mm (9.31inch)
Power supply	110/220v 50/60Hz
Pump type	Electric oil-less vacuum pump with carbon fiber vanes
Designed operating pressure	20in.Hg (10 psi)
Cable length	5m / 15 foot of flex
Hose Length	30 foot length
Pump Weight	25kg



Société Internationale de Produits et services Industriels

102 rue J.-B. Charcot

92400 Courbevoie - France

☎ : (33°) 01 47 68 75 00

✉ : ipsi@ipsifrance.com

☎ : (33) 01 47 89 99 39

🌐 : www.ipsifrance.com

VACUUM BOX by model

Vac Box Model number :	V400C
Physical Dimensions	L 660 x W 310 x H 380 mm
Weight	8,95 Kg
Pressure Rating	20 inch Hg



Vac Box Model number :	V400LP
Physical Dimensions	L 540 x W 220 x H 220 mm
Weight	4,00 Kg
Pressure Rating	10 inch Hg

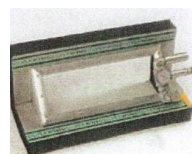

AIR COMPRESSOR GENERATED VACUUM BOXES

Vac Box Model number :	V600FAVG
Physical Dimensions	L 780 x W 300 x H 230 mm
Weight	11,30 Kg
Pressure Rating	20 inch Hg

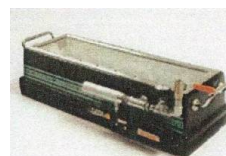

Vac Box Model number :	V600LPAVG
Physical Dimensions	L 660 x W 220 x H 250 mm
Weight	2,75 Kg
Pressure Rating	10 inch Hg



Vac Box Model number :	V400CAVG
Physical Dimensions	L 660 x W 310 x H 390 mm
Weight	9,15 Kg
Pressure Rating	20 inch Hg



Vac Box Model number :	V400PLAVG
Physical Dimensions	L 540 x W 230 x H 230 mm
Weight	4,25 Kg
Pressure Rating	10 inch Hg

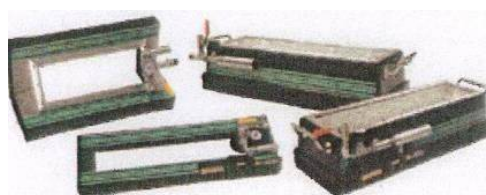

Société Internationale de Produits et services Industriels

102 rue J.-B. Charcot

92400 Courbevoie - France

☎ : (33) 01 47 68 75 00

✉ : ipsi@ipsifrance.com

☎ : (33) 01 47 89 99 39

🌐 : www.ipsifrance.com